

5KP SERIES

V_{RM} : 5.0 - 180 Volts
PPK : 5000 Watts

FEATURES :

- * 5000W Peak Pulse Power
- * Excellent clamping capability
- * Low incremental surge resistance
- * Fast response time : typically less than 1.0 ps from 0 volt to V_{BR(min.)}
- * Typical I_R less than 1μA above 10V

MECHANICAL DATA

- * Case : Molded plastic
- * Epoxy : UL94V-0 rate flame retardant
- * Lead : Axial lead solderable per MIL-STD-202, Method 208 guaranteed
- * Polarity : Cathode polarity band
- * Mounting position : Any
- * Weight : 2.1 grams

DEVICES FOR BIPOLAR APPLICATIONS

For Bi-directional use C or CA Suffix
 Electrical characteristics apply in both directions

MAXIMUM RATINGS

Rating at 25 °C ambient temperature unless otherwise specified.

Rating	Symbol	Value	Unit
Peak Pulse Power Dissipation at tp = 1ms (Note 1, Fig. 4)	P _{PK}	Minimum 5000	W
Steady State Power Dissipation at T _L = 75 °C Lead Lengths 0.375", (9.5mm) (Note 2)	P _D	8.0	W
Peak Forward Surge Current, 8.3ms Single Half Sine-Wave Superimposed on Rated Load (JEDEC Method) (Note 3)	I _{FSM}	400	A
Operating and Storage Temperature Range	T _J , T _{STG}	- 55 to + 150	°C

Notes:

- (1) Non-repetitive Current pulse, per Fig. 5 and derated above Ta = 25 °C per Fig. 1
- (2) Mounted on Copper Leaf area of 0.79 in² (20mm²).
- (3) Measured on 8.3 ms single half sine-wave or equivalent square wave, duty cycle = 4 pulses per minutes maximum.

TRANSIENT VOLTAGE SUPPRESSOR

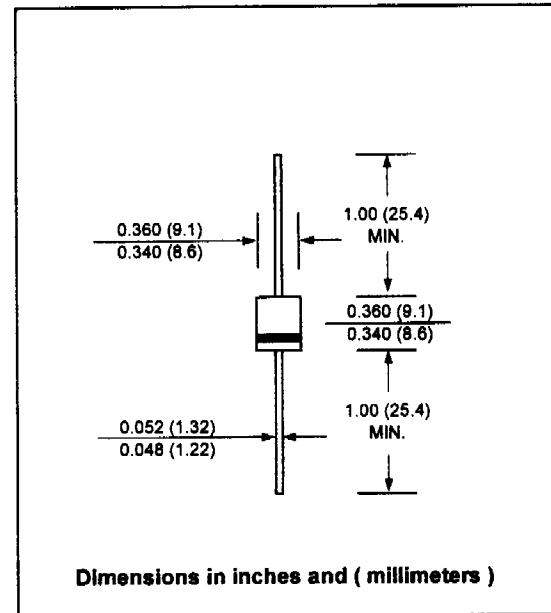

ELECTRICAL CHARACTERISTICS

Rating at 25 °C ambient temperature unless otherwise specified

TYPE	Breakdown Voltage @ I _T (Note 1)		Reverse Stand off Voltage	Maximum Reverse Leakage @ V _{RM}	Maximum Peak Pulse Current (Note2)	Maximum Clamping Voltage @ I _{PPM}	Maximum Temperature Coefficient of V _{BR} (%/°C)	
	V _{BR} (V)							I _T
	Min.	Max.	(mA)	(V)	(μA)	(A)		(V)
5KP5.0	6.40	7.30	50	5.0	5000	620	9.60	0.057
5KP5.0A	6.40	7.00	50	5.0	5000	543	9.20	0.057
5KP6.0	6.67	8.15	50	6.0	5000	439	11.4	0.061
5KP6.0A	6.67	7.37	50	6.0	5000	485	10.3	0.061
5KP6.6	7.22	8.82	50	6.5	2000	407	12.3	0.065
5KP6.6A	7.22	7.98	50	6.5	2000	447	11.2	0.065
5KP7.0	7.78	9.51	5.0	7.0	1000	378	13.3	0.068
5KP7.0A	7.78	8.80	5.0	7.0	1000	417	12.0	0.068
5KP7.6	8.33	10.2	5.0	7.5	250	350	14.3	0.073
5KP7.6A	8.33	9.21	5.0	7.5	250	388	12.9	0.073
5KP8.0	8.89	10.9	5.0	8.0	150	333	15.0	0.075
5KP8.0A	8.89	9.83	5.0	8.0	150	367	13.6	0.075
5KP8.6	9.44	11.5	5.0	8.5	50	314	15.9	0.078
5KP8.6A	9.44	10.4	5.0	8.5	50	347	14.4	0.078
5KP9.0	10.0	12.2	5.0	9.0	20	295	16.9	0.081
5KP9.0A	10.0	11.1	5.0	9.0	20	325	15.4	0.081
5KP10	11.1	13.6	5.0	10	15	266	18.8	0.084
5KP10A	11.1	12.3	5.0	10	15	294	17.0	0.084
5KP11	12.2	14.9	5.0	11	10	249	20.1	0.086
5KP11A	12.2	13.5	5.0	11	10	274	18.2	0.086
5KP12	13.3	16.3	5.0	12	10	227	22.0	0.088
5KP12A	13.3	14.7	5.0	12	10	251	19.9	0.088
5KP13	14.4	17.6	5.0	13	10	210	23.8	0.090
5KP13A	14.4	15.9	5.0	13	10	232	21.5	0.090
5KP14	15.6	19.1	5.0	14	10	194	25.8	0.092
5KP14A	15.6	17.2	5.0	14	10	215	23.2	0.092
5KP16	16.7	20.4	5.0	15	10	188	26.9	0.094
5KP16A	16.7	18.5	5.0	15	10	206	24.4	0.094
5KP16	17.8	21.8	5.0	16	10	176	28.8	0.096
5KP16A	17.8	19.7	5.0	16	10	192	26.0	0.096
5KP17	18.9	23.1	5.0	17	10	164	30.5	0.097
5KP17A	18.9	20.9	5.0	17	10	181	27.6	0.097
5KP18	20.0	24.4	5.0	18	10	155	32.2	0.098
5KP18A	20.0	22.1	5.0	18	10	172	29.2	0.098
5KP20	22.2	27.1	5.0	20	10	139	35.8	0.099
5KP20A	22.2	24.5	5.0	20	10	154	32.4	0.099
5KP22	24.4	29.8	5.0	22	10	127	39.4	0.100
5KP22A	24.4	26.9	5.0	22	10	141	35.5	0.100
5KP24	26.7	32.6	5.0	24	10	116	43.0	0.101
5KP24A	26.7	29.5	5.0	24	10	128	38.9	0.101
5KP26	28.9	35.3	5.0	26	10	107	46.6	0.101
5KP26A	28.9	31.9	5.0	26	10	119	42.1	0.101
5KP28	31.1	38.0	5.0	28	10	99	50.1	0.102
5KP28A	31.1	34.4	5.0	28	10	110	45.4	0.102
5KP30	33.3	40.7	5.0	30	10	93	53.5	0.103
5KP30A	33.3	36.8	5.0	30	10	103	48.4	0.103
5KP33	36.7	44.9	5.0	33	10	85	59.0	0.104
5KP33A	36.7	40.6	5.0	33	10	94	53.3	0.104

ELECTRICAL CHARACTERISTICS

Rating at 25 °C ambient temperature unless otherwise specified

TYPE	Breakdown Voltage @ I_T (Note 1)		Reverse Stand off Voltage	Maximum Reverse Leakage @ V_{RM}	Maximum Peak Pulse Current (Note2)	Maximum Clamping Voltage @ I_{PPM}	Maximum Temperature Coefficient of V_{BR} (%/°C)	
	V_{BR} (V)							I_T
	Min.	Max.	(mA)	(V)	(μ A)	(A)	(V)	
5KP36	40.0	48.9	5.0	36	10	78	64.3	0.104
5KP36A	40.0	44.2	5.0	36	10	86	58.1	0.104
5KP40	44.4	54.3	5.0	40	10	70	71.4	0.105
5KP40A	44.4	49.1	5.0	40	10	78	64.5	0.105
5KP43	47.8	58.4	5.0	43	10	65	76.7	0.105
5KP43A	47.8	52.8	5.0	43	10	72	69.4	0.105
5KP45	50.0	61.1	5.0	45	10	62	80.3	0.106
5KP45A	50.0	55.3	5.0	45	10	69	72.7	0.106
5KP48	53.3	65.2	5.0	48	10	58	85.5	0.106
5KP48A	53.3	58.9	5.0	48	10	65	77.4	0.106
5KP51	56.7	69.3	5.0	51	10	55	91.1	0.107
5KP51A	56.7	62.7	5.0	51	10	61	82.4	0.107
5KP54	60.0	73.3	5.0	54	10	52	96.3	0.107
5KP54A	60.0	66.3	5.0	54	10	57	87.1	0.107
5KP56	62.2	76.1	5.0	56	10	50	100	0.107
5KP56A	62.2	68.8	5.0	56	10	55	91	0.107
5KP58	64.4	78.7	5.0	58	10	49	103	0.107
5KP58A	64.4	71.2	5.0	58	10	53	94	0.107
5KP60	66.7	81.5	5.0	60	10	47	107	0.108
5KP60A	66.7	73.7	5.0	60	10	52	97	0.108
5KP64	71.1	96.9	5.0	64	10	44	114	0.108
5KP64A	71.1	78.6	5.0	64	10	49	103	0.108
5KP70	77.6	95.1	5.0	70	10	40	125	0.108
5KP70A	77.6	86.0	5.0	70	10	44	113	0.108
5KP75	83.3	102	5.0	75	10	37	134	0.108
5KP75A	83.3	92.1	5.0	75	10	41	121	0.108
5KP78	86.7	106	5.0	78	10	36	139	0.108
5KP78A	86.7	95.8	5.0	78	10	40	126	0.108
5KP85	94.4	115	5.0	85	10	33	151	0.108
5KP85A	94.4	104	5.0	85	10	36	137	0.110
5KP90	100	122	5.0	90	10	31	160	0.110
5KP90A	100	111	5.0	90	10	34	146	0.110
5KP100	111	136	5.0	100	10	28	179	0.110
5KP100A	111	123	5.0	100	10	31	162	0.110
5KP110	122	149	5.0	110	10	26	196	0.112
5KP110A	122	135	5.0	110	10	28	177	0.112
5KP120	133	163	5.0	120	10	24	211	0.112
5KP120A	133	147	5.0	120	10	26	194	0.112
5KP150	167	204	5.0	150	10	19	263	0.112
5KP150A	167	184	5.0	150	10	21	242	0.112
5KP160	178	217	5.0	160	10	18	281	0.114
5KP160A	178	196	5.0	160	10	19	258	0.114
5KP180	200	244	5.0	180	10	16	316	0.114
5KP180A	200	221	5.0	180	10	17	290	0.114

Notes:

- (1) V_{BR} measured after I_T applied for 300 μ s., I_T = square wave pulse or equivalent.
- (2) Surge Current waveform per Fig. 3 and Derate per Fig. 2
- (3) V_F = 3.5 Volts max. for devices of V_R < 100 V, and V_F = 5 Volts max. for devices of V_R > 100 V.
- (4) For Bi-directional devices having V_R of 10 Volts and under the I_R limit is doubled.

RATING AND CHARACTERISTIC CURVES (5KP SERIES)

FIG.1 - PULSE DERATING CURVE

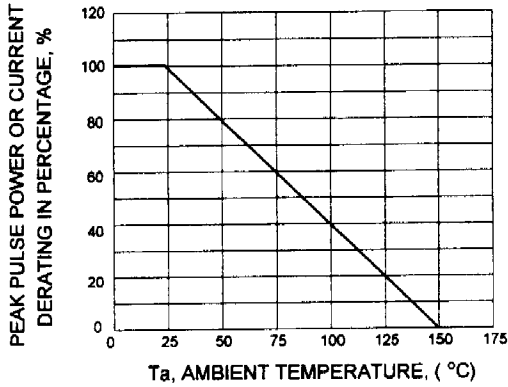

FIG.2 - MAXIMUM NON-REPETITIVE PEAK FORWARD SURGE CURRENT

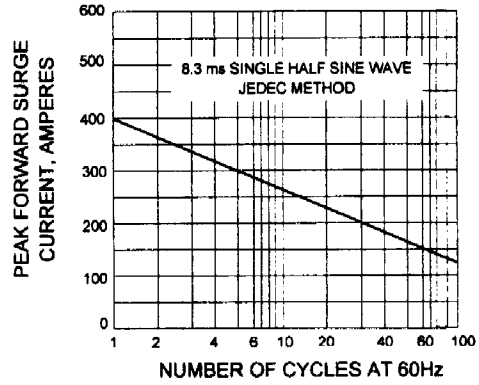

FIG.3 - STEADY STATE POWER DERATING

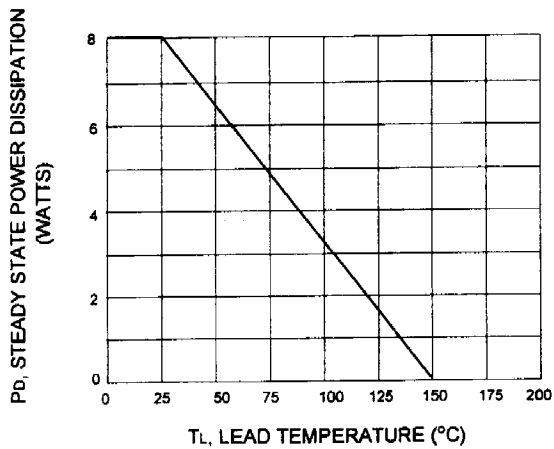

FIG.4 - PEAK PULSE POWER RATING CURVE

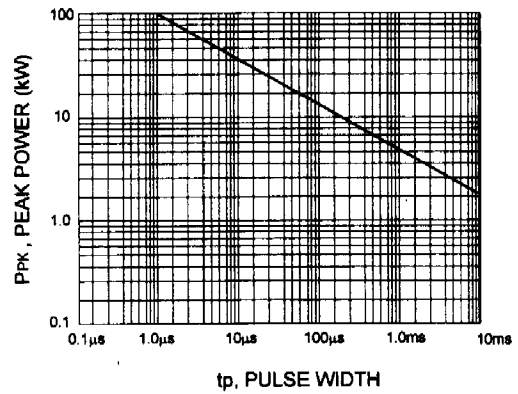

FIG.5 - PULSE WAVEFORM

