

UNI-AND BIDIRECTIONAL TRANSIENT VOLTAGE SUPPRESSORS

- HIGH SURGE CAPABILITY :
5 kW / 1 ms EXPO
- VERY FAST CLAMPING TIME :
1 ps FOR UNIDIRECTIONAL TYPES
5 ns FOR BIDIRECTIONAL TYPES
- LARGE VOLTAGE RANGE :
10 V → 180 V
- ORDER CODE :
TYPE NUMBER FOR UNIDIRECTIONAL
TYPES, TYPE NUMBER + SUFFIX B FOR
BIDIRECTIONAL TYPES

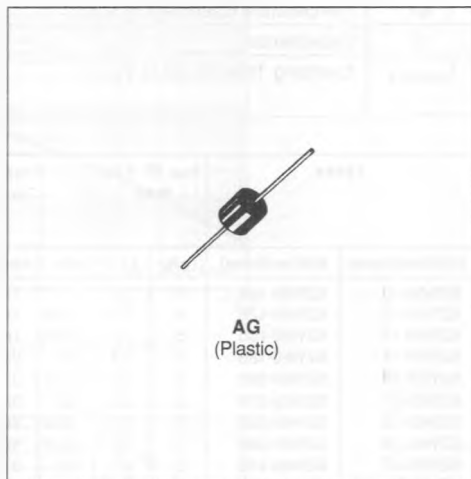

DESCRIPTION

Transient voltage suppressor diodes especially useful in protecting integrated circuits, MOS, hybrids and other voltage-sensitive semiconductors and components.

ABSOLUTE RATINGS (limiting values)

Symbol	Parameter		Value	Unit
P_D	Peak Pulse Power for 1 ms Exponential Pulse	T_j Initial = 25 °C See note 1	5	kW
P	Power Dissipation on Infinite Heatsink	$T_{amb} = 75$ °C	5	W
I_{FSM}	Non Repetitive Surge Peak Forward Current for Unidirectional Types	T_j Initial = 25 °C $t = 10$ ms	500	A
T_{stg} T_j	Storage and Operating Junction Temperature Range		- 65 to 150 150	°C °C
T_L	Maximum Lead Temperature for Soldering During 10 s at 4 mm from Case		230	°C

THERMAL RESISTANCE

Symbol	Parameter	Value	Unit
$R_{th(j-l)}$	Junction-leads on Infinite Heatsink for $L_{lead} = 10$ mm	15	°C/W

Note : 1. For surges upper than the maximum values, the diode will present a short-circuit anode-cathode.

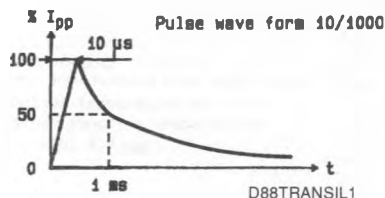

ELECTRICAL CHARACTERISTICS (T_J = 25 °C)

Symbol	Parameter	Value	
V _{RM}	Stand-off Voltage	See tables	
V _(BR)	Breakdown Voltage		
V _(CL)	Clamping Voltage		
I _{pp}	Peak Pulse Current		
α _T	Temperature Coefficient of V _(BR)		
C	Capacitance		
t _{clamping}	Clamping Time (0 volt to V _(BR))	Unidirectional Types	1 ps max.
		Bidirectional Types	5 ns max.

Types		I _{RM} @ V _{RM} max.		V _(BR) * @ I _R (V)			V _(CL) @ I _{pp} max. 1 ms expo		V _(CL) @ I _{pp} max. 8-20 μs expo		α _T max.	C** typ. V _R =0 f=1 MHz	
Unidirectional	Bidirectional	(μA)	(V)	min.	nom.	max.	(mA)	(V)	(A)	(V)	(A)	(10 ⁻⁴ /°C)	(pF)
BZW50-10	BZW50-10B	5	10	11.1	12.4	13.6	1	18.8	266	23.4	2564	7.8	24000
BZW50-12	BZW50-12B	5	12	13.3	14.8	16.3	1	22	227	28	2143	8.4	18500
BZW50-15	BZW50-15B	5	15	16.6	18.5	20.4	1	26.9	186	35	1714	8.8	13500
BZW50-18	BZW50-18B	5	18	20	22.2	24.4	1	32.2	155	41.5	1446	9.2	11500
BZW50-22	BZW50-22B	5	22	24.4	27.1	29.8	1	39.4	127	51	1177	9.6	8500
BZW50-27	BZW50-27B	5	27	30	33.3	36.6	1	48.3	103	62	968	9.8	7000
BZW50-33	BZW50-33B	5	33	36.6	40.7	44.7	1	59	85	76	789	10	5750
BZW50-39	BZW50-39B	5	39	43.3	48.1	53	1	69.4	72	90	667	10.1	4800
BZW50-47	BZW50-47B	5	47	52	57.8	63.6	1	83.2	60.1	108	556	10.3	4100
BZW50-56	BZW50-56B	5	56	62.2	69.1	76	1	99.6	50	129	465	10.4	3400
BZW50-68	BZW50-68B	5	68	75.6	84	92.4	1	121	41	157	382	10.5	3000
BZW50-82	BZW50-82B	5	82	91	101.2	111	1	145	34	189	317	10.6	2600
BZW50-100	BZW50-100B	5	100	111	123.5	136	1	179	28	228	263	10.7	2300
BZW50-120	BZW50-120B	5	120	133	148.1	163	1	215	23	274	219	10.8	1900
BZW50-150	BZW50-150B	5	150	166	185.2	204	1	269	19	343	175	10.8	1700
BZW50-180	BZW50-180B	5	180	200	222	244	1	322	16	410	146	10.8	1500

* Pulse test t_p ≤ 50 ms δ < 2 %.

** Divide these values by 2 for bidirectional types.

For bidirectional types, electrical characteristics apply in both directions.

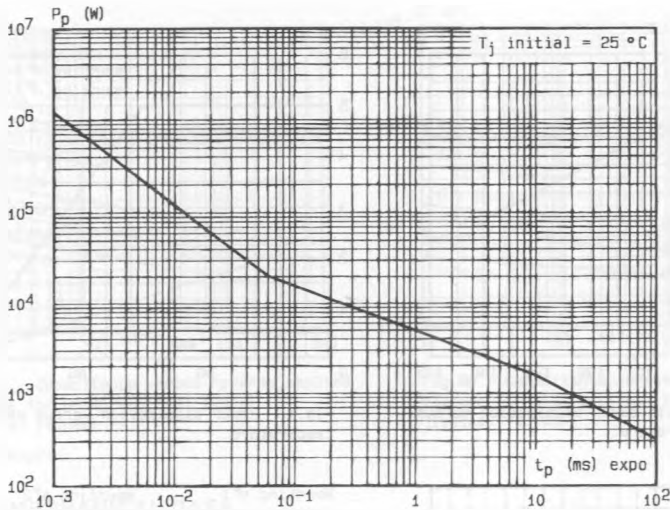

Fig.1 - Peak pulse power versus exponential pulse duration.

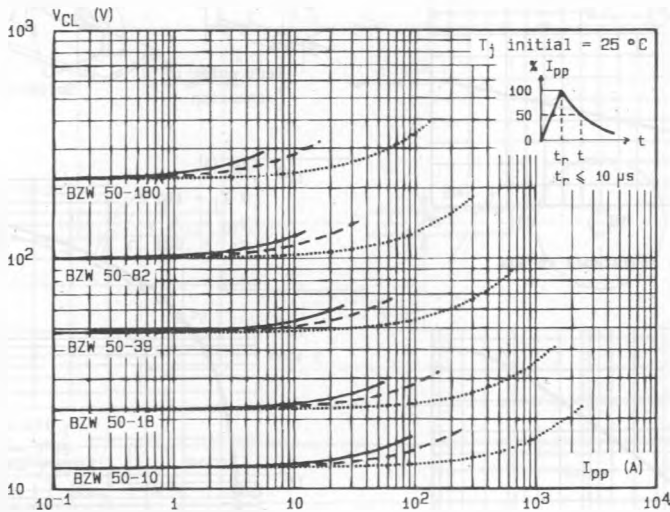

Fig.2 - Clamping voltage versus peak pulse current.
 exponential waveform $t = 20 \mu s$.
 $t = 1 ms$ - - - -
 $t = 10 ms$ ———

Note : The curves of the figure 2 are specified for a junction temperature of 25 °C before surge. The given results may be extrapolated for other junction temperatures by using the following formula : $\Delta V (BR) = \alpha T (V (BR)) \times [T_j - 25] \times V (BR)$
 For intermediate voltages, extrapolate the given results.

D88BZW50P3

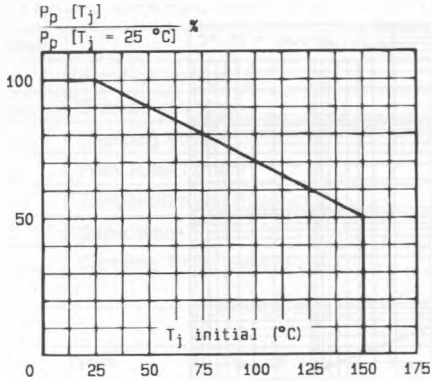

Fig.3 - Allowable power dissipation versus junction temperature.

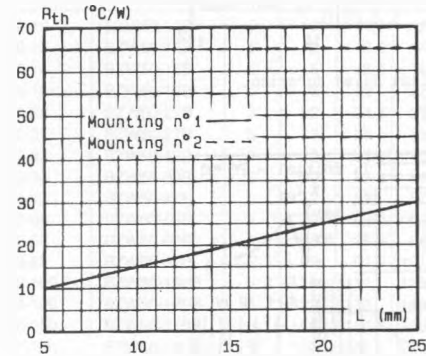

Fig.5 - Thermal resistance versus lead length.

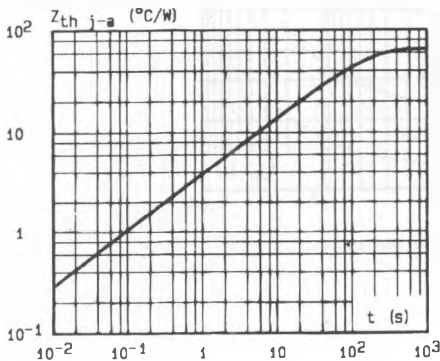

Fig.6 - Transient thermal impedance junction-ambient for mounting n°2 versus pulse duration (L = 10 mm).

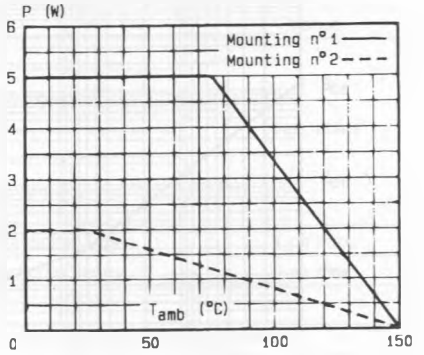

Fig.4 - Power dissipation versus ambient temperature.

Mounting n°1 INFINITE HEATSINK
Mounting n°2 PRINTED CIRCUIT

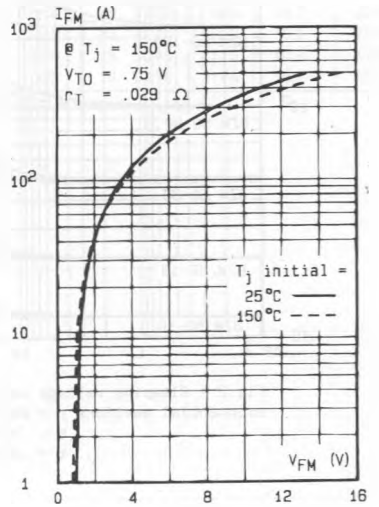
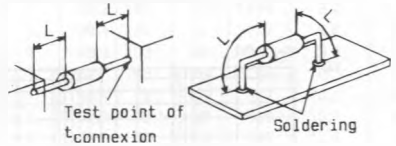

Fig.7 - Peak forward current versus peak forward voltage drop (typical values for unidirectional types).

D88BZW50P4

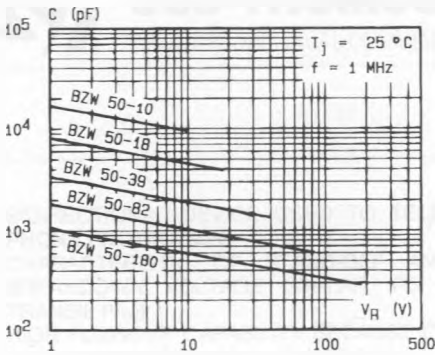

Fig.8a - Capacitance versus reverse applied voltage for unidirectional types (typical values).

D88BZW50P5

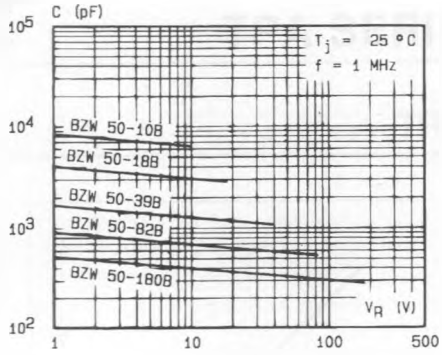
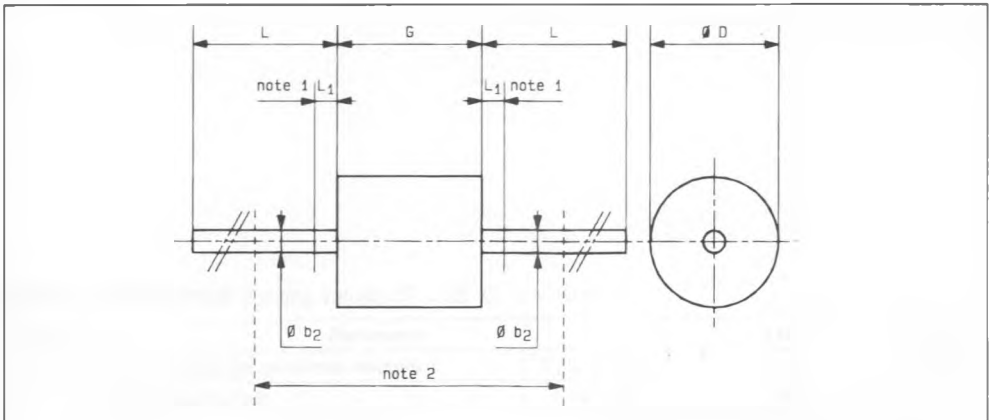

Fig.8b - Capacitance versus reverse applied voltage for bidirectional types (typical values).

PACKAGE MECHANICAL DATA

AG Plastic



Ref.	Millimeters		Inches		Notes
	Min.	Max.	Min.	Max.	
∅ b ₂	1.35	1.45	0.053	0.057	1 - The lead diameter ∅ b ₂ is not controlled over zone L ₁ . 2 - The minimum axial length within which the device may be placed with its leads bent at right angles is 0.79" (20 mm).
∅ D	-	8	-	0.315	
G	-	9	-	0.354	
L	20	-	0.787	-	
L ₁	-	1.27	-	0.050	

Cooling method : by convection (method A).

Marking : type number ; white band indicates cathode for unidirectional types.

Weight : 1 g.