

Super Fast Soft Recovery Rectifier

Features

- Glass passivated
- Hermetically sealed axial leaded glass envelope
- Low reverse current
- High reverse voltage

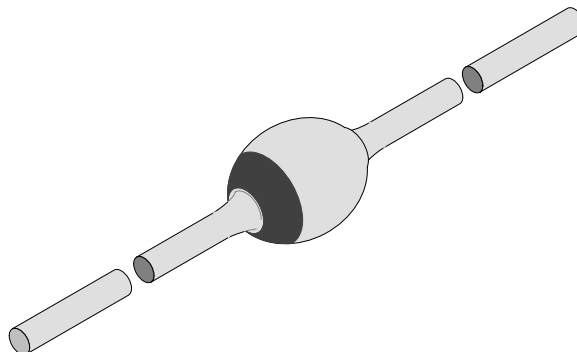

94 9539

Applications

Switched mode power supplies
High-frequency inverter circuits

Absolute Maximum Ratings

$T_j = 25^\circ\text{C}$

Parameter	Test Conditions	Type	Symbol	Value	Unit
Repetitive peak reverse voltage		SF4001	V_{RRM}	50	V
		SF4002	V_{RRM}	100	V
		SF4003	V_{RRM}	200	V
		SF4004	V_{RRM}	400	V
		SF4005	V_{RRM}	600	V
		SF4006	V_{RRM}	800	V
		SF4007	V_{RRM}	1000	V
Reverse voltage		SF4001	V_R	50	V
		SF4002	V_R	100	V
		SF4003	V_R	200	V
		SF4004	V_R	400	V
		SF4005	V_R	600	V
		SF4006	V_R	800	V
		SF4007	V_R	1000	V
Peak forward surge current	$t_p=10$ ms, half sinewave		I_{FSM}	30	A
Average forward current	Lead length $l = 10$ mm, $T_L = 25^\circ\text{C}$		I_{FAV}	1	A
Junction temperature			T_j	175	$^\circ\text{C}$
Storage temperature range			T_{stg}	-55...+175	$^\circ\text{C}$

Maximum Thermal Resistance

$T_j = 25^\circ\text{C}$

Parameter	Test Conditions	Symbol	Value	Unit
Junction ambient	Lead length $l = 10$ mm, $T_L = \text{constant}$	R_{thJA}	45	K/W
	mounted on epoxy-glass hard tissue, Fig. 1, $d = 25$ mm	R_{thJA}	100	K/W

Characteristics

$T_j = 25^\circ\text{C}$

Parameter	Test Conditions	Type	Symbol	Min	Typ	Max	Unit
Forward voltage	$I_F = 1\text{ A}$	SF4001	V_F			1	V
		SF4002	V_F			1	V
		SF4003	V_F			1	V
		SF4004	V_F			1	V
		SF4005	V_F			1.7	V
		SF4006	V_F			1.7	V
		SF4007	V_F			1.7	V
Reverse current	$V_R = V_{RRM}$		I_R			5	μA
	$V_R = V_{RRM}, T_j = 125^\circ\text{C}$		I_R			50	μA
Reverse breakdown voltage	$I_R = 100\mu\text{A}$	SF4001	$V_{(BR)R}$	50			V
		SF4002	$V_{(BR)R}$	100			V
		SF4003	$V_{(BR)R}$	200			V
		SF4004	$V_{(BR)R}$	400			V
		SF4005	$V_{(BR)R}$	600			V
		SF4006	$V_{(BR)R}$	800			V
		SF4007	$V_{(BR)R}$	1000			V
Reverse recovery time	$I_F = 0.5\text{ A}, I_R = 1\text{ A},$ $i_R = 0.25\text{ A}$	SF4001	t_{rr}			50	ns
		SF4002	t_{rr}			50	ns
		SF4003	t_{rr}			50	ns
		SF4004	t_{rr}			50	ns
		SF4005	t_{rr}			75	ns
		SF4006	t_{rr}			75	ns
		SF4007	t_{rr}			75	ns

Typical Characteristics ($T_j = 25^\circ\text{C}$ unless otherwise specified)

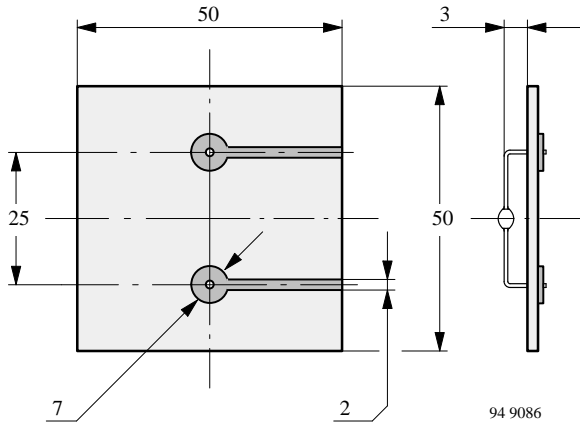

Figure 1. Epoxy glass hard tissue, board thickness 1.5 mm,
 $R_{thJA} \leq 100 \text{ K/W}$

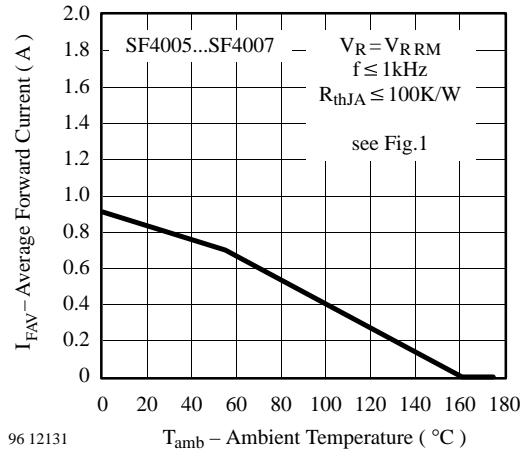

Figure 4. Average Forward Current vs. Ambient Temperature

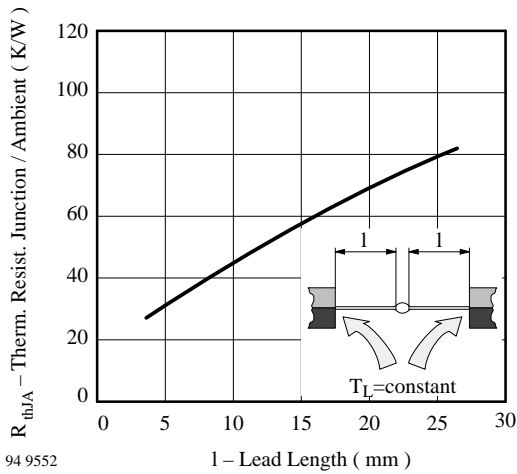

Figure 2. Thermal Resistance vs. Lead Length

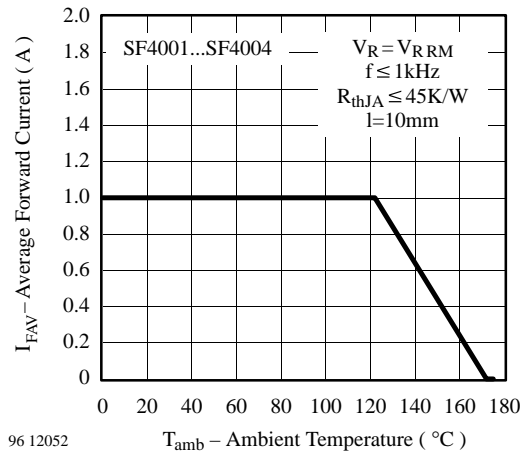

Figure 5. Average Forward Current vs. Ambient Temperature

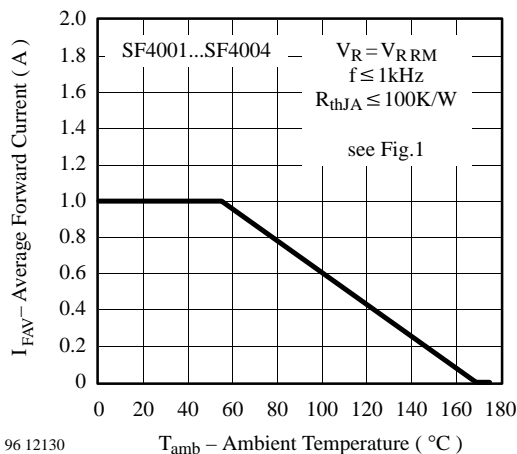

Figure 3. Average Forward Current vs. Ambient Temperature

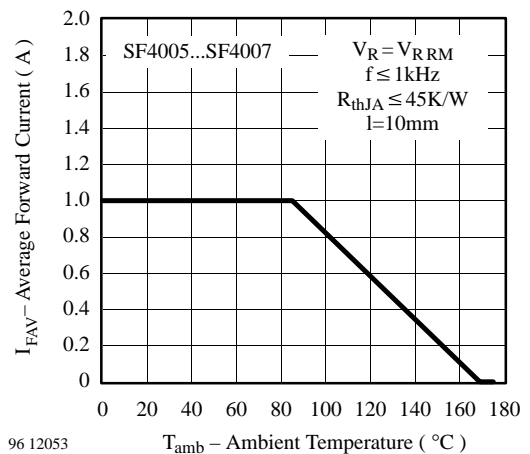

Figure 6. Average Forward Current vs. Ambient Temperature

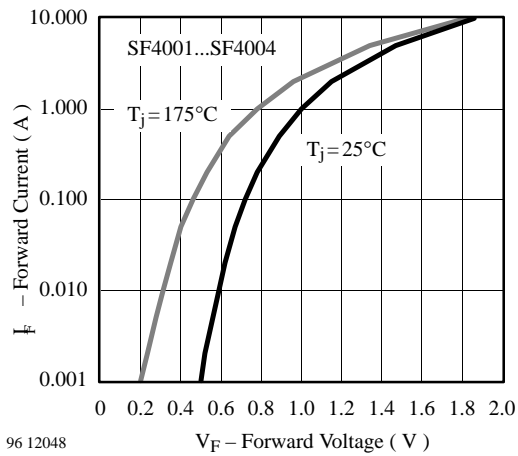

Figure 7. Forward Current vs. Forward Voltage

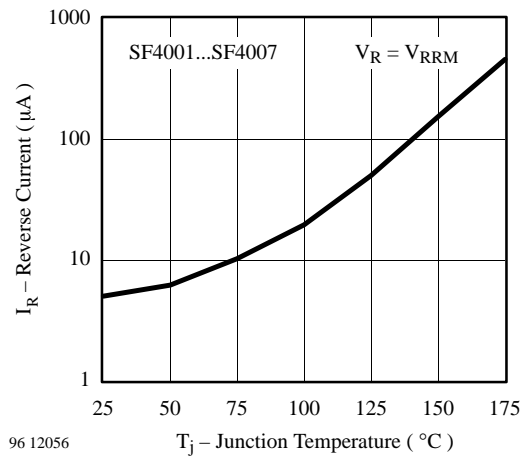

Figure 9. Reverse Current vs. Junction Temperature

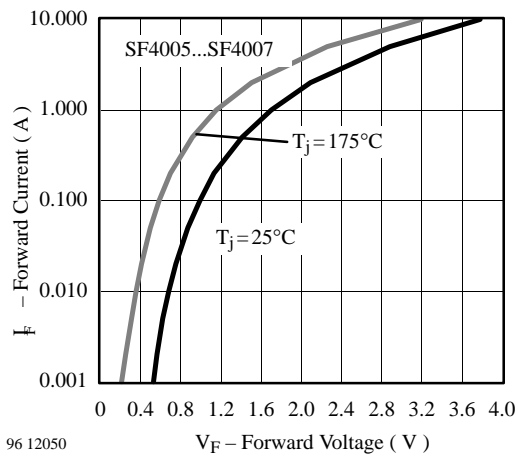
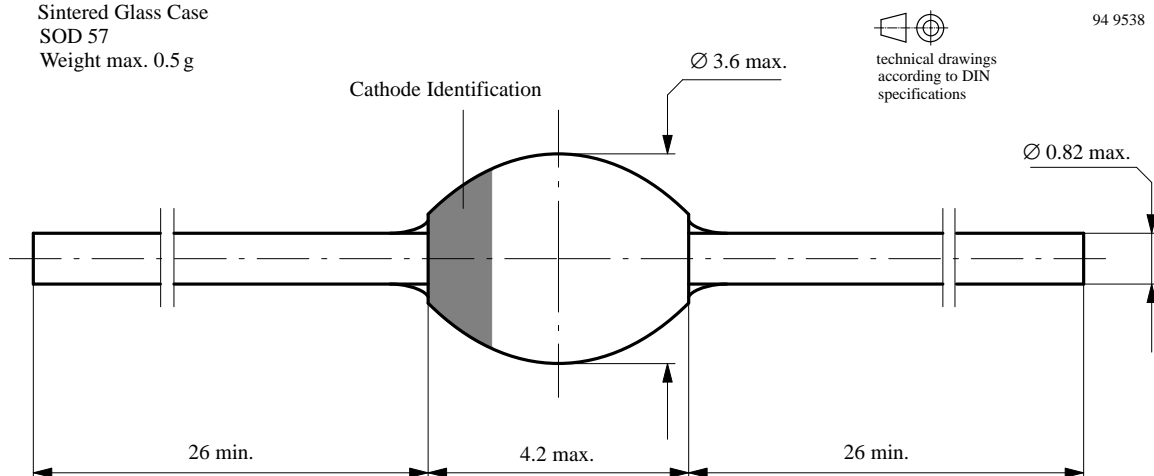

Figure 8. Forward Current vs. Forward Voltage

Dimensions in mm

Sintered Glass Case
SOD 57
Weight max. 0.5 g



technical drawings
according to DIN
specifications

94 9538

Ozone Depleting Substances Policy Statement

It is the policy of **TEMIC TELEFUNKEN microelectronic GmbH** to

1. Meet all present and future national and international statutory requirements.
2. Regularly and continuously improve the performance of our products, processes, distribution and operating systems with respect to their impact on the health and safety of our employees and the public, as well as their impact on the environment.

It is particular concern to control or eliminate releases of those substances into the atmosphere which are known as ozone depleting substances (ODSs).

The Montreal Protocol (1987) and its London Amendments (1990) intend to severely restrict the use of ODSs and forbid their use within the next ten years. Various national and international initiatives are pressing for an earlier ban on these substances.

TEMIC TELEFUNKEN microelectronic GmbH semiconductor division has been able to use its policy of continuous improvements to eliminate the use of ODSs listed in the following documents.

1. Annex A, B and list of transitional substances of the Montreal Protocol and the London Amendments respectively
2. Class I and II ozone depleting substances in the Clean Air Act Amendments of 1990 by the Environmental Protection Agency (EPA) in the USA
3. Council Decision 88/540/EEC and 91/690/EEC Annex A, B and C (transitional substances) respectively.

TEMIC can certify that our semiconductors are not manufactured with ozone depleting substances and do not contain such substances.

We reserve the right to make changes to improve technical design and may do so without further notice.

Parameters can vary in different applications. All operating parameters must be validated for each customer application by the customer. Should the buyer use TEMIC products for any unintended or unauthorized application, the buyer shall indemnify TEMIC against all claims, costs, damages, and expenses, arising out of, directly or indirectly, any claim of personal damage, injury or death associated with such unintended or unauthorized use.

TEMIC TELEFUNKEN microelectronic GmbH, P.O.B. 3535, D-74025 Heilbronn, Germany
Telephone: 49 (0)7131 67 2831, Fax number: 49 (0)7131 67 2423