

Fast Recovery Rectifier Diodes

SKN 135 F SKR 135 F
 SKN 136 F SKR 136 F
 SKN 140 F SKR 140 F
 SKN 141 F SKR 141 F



Features

- Small recovered charge
- Soft recovery
- Up to 1500 V reverse voltage
- Hermetic metal cases with glass insulators
- Threaded studs M12
- SKN: anode to stud
SKR: cathode to stud

Typical Applications

- Inverse diodes for GTO and asymmetric thyristors
- Inverters and choppers
- A. C. motor control, uninterruptible power supplies (UPS)

V _{RSM} V _{RRM}	IFRMS (maximum values for continuous operation) 260 A			
	I _{FAV} (sin. 180; T _{case} = 85 °C)			
	160 A		168 A	
	t _{rr} = 500 ns		t _{rr} = 800 ns	
V				
800	SKN 135 F 08 SKN 136 F 08	SKR 135 F 08 SKR 136 F 08	-	-
1000	SKN 135 F 10 SKN 136 F 10	SKR 135 F 10 SKR 136 F 10	-	-
1200	SKN 135 F 12 SKN 136 F 12	SKR 135 F 12 SKR 136 F 12	SKN 140 F 12 SKN 141 F 12	SKR 140 F 12 SKR 141 F 12
1400	-	-	SKN 140 F 14 SKN 141 F 14	SKR 140 F 14 SKR 141 F 14
1500	-	-	SKN 140 F 15 SKN 141 F 15	SKR 140 F 15 SKR 141 F 15

Symbol	Conditions	SKN135F SKR135F SKN136F SKR136F	SKN140F SKR140F SKN141F SKR141F	Units
I _{FAV}	sin. 180; T _{case} = 85 °C; 1000 Hz T _{case} = 100 °C; 1000 Hz sin. 180/ rec. 120 T _{amb} = 45 °C; K 1,1 P 1/200 K 0,55 T _{amb} = 35 °C; P 1/120 F K 1,1 F	160 135	168 140	A A
I _{FSM}	T _{Vj} = 25 °C; 10 ms T _{Vj} = 150 °C; 10 ms	2500 2100	2500 2100	A A
i ² t	T _{Vj} = 25 °C; 8,3 ... 10 ms T _{Vj} = 150 °C; 8,3 ... 10 ms	31000 22000	31000 22000	A ² s A ² s
Q _{rr}	T _{Vj} = 150 °C V _R = 400 V	50 75	90 135	μC μC
I _{RM}	$-\frac{di}{dt} = 100 \frac{A}{\mu s}$ I _F = 100 A I _F = 300 A	53 69	90 115	A A
I _R	T _{Vj} = 25 °C; V _R = V _{RRM} T _{Vj} = 150 °C; V _R = V _{RRM}	1 100	1 100	mA mA
t _{rr}	T _{Vj} = 25 °C T _{Vj} = 150 °C I _F = I _R = 1 A	max. 500 typ. 1	max. 800 typ. 1,6	ns μs
V _F	T _{Vj} = 25 °C; I _F = 300 A	max. 1,95	max. 1,80	V
V _(TO)	T _{Vj} = 150 °C	1,1	1,1	V
r _T	T _{Vj} = 150 °C	2,3	2	mΩ
R _{thjc}		0,2		°C/W
R _{thch}		0,08		°C/W
T _{Vj}		- 40 ... + 150		°C
T _{stg}		- 55 ... + 150		°C
M	SI (US) units	10 (90 lb.in.)		Nm
a		5 · 9,81		m/s ²
w	approx.	100		g
Case	135 F, 140 F 136 F, 141 F	E 14 E 31		

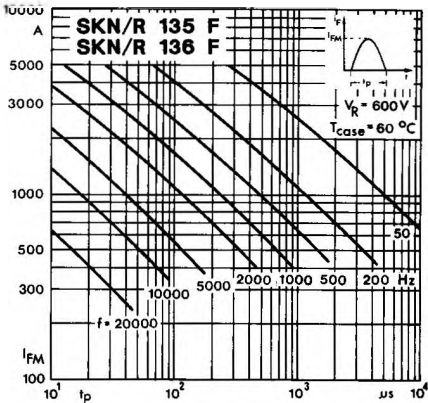

Fig. 1 a Rated sinusoidal peak forward current

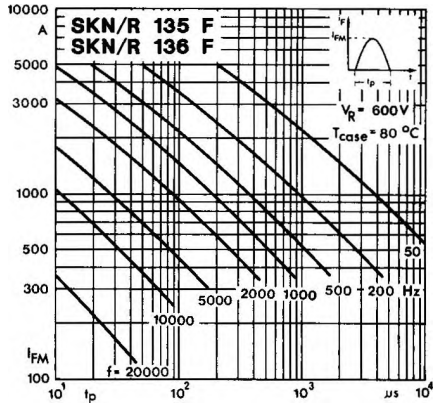

Fig. 1 b Rated sinusoidal peak forward current

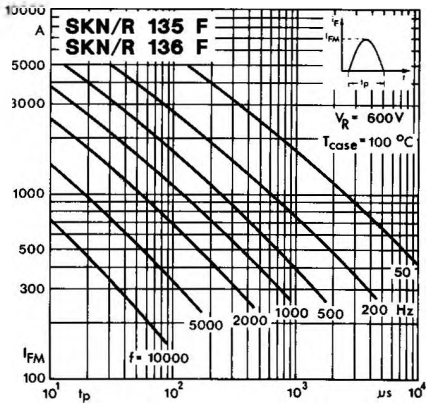

Fig. 1 c Rated sinusoidal peak forward current

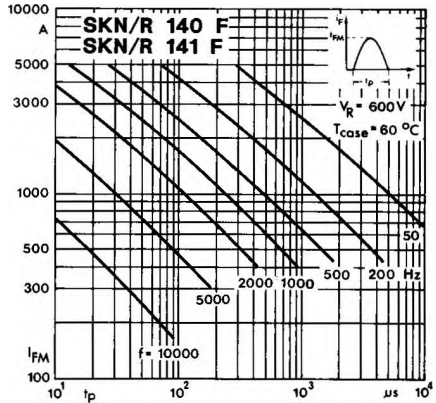

Fig. 1 d Rated sinusoidal peak forward current

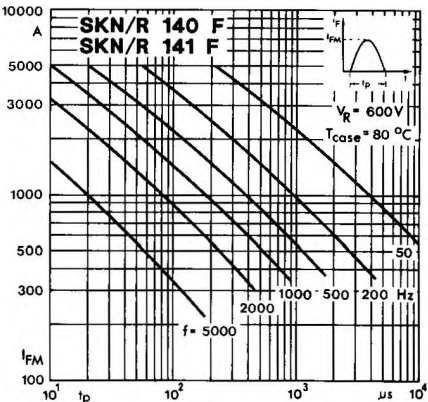

Fig. 1 e Rated sinusoidal peak forward current

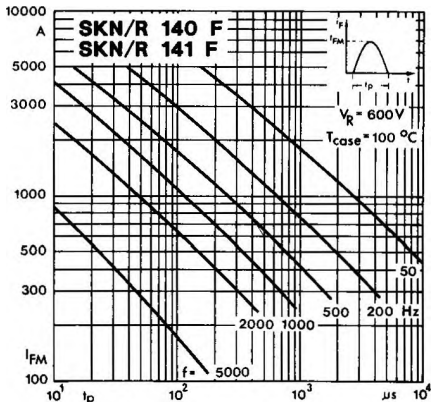

Fig. 1 f Rated sinusoidal peak forward current

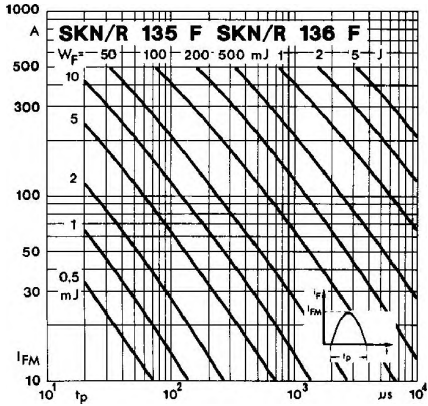

Fig. 2 a Forward energy dissipation, sinusoidal

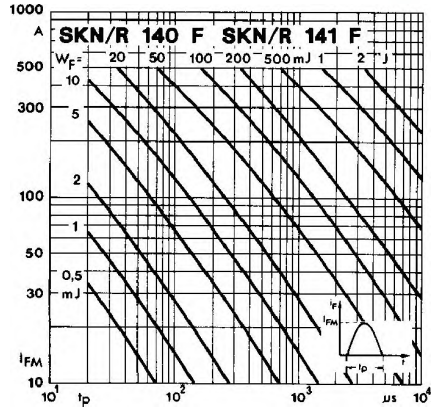

Fig. 2 b Forward energy dissipation, sinusoidal

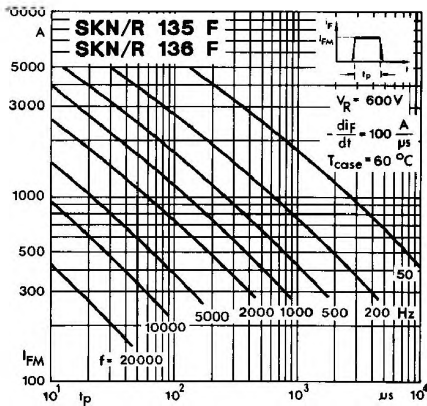

Fig. 3 a Rated rectangular peak forward current

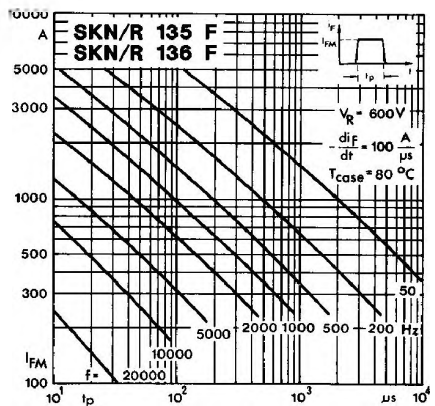

Fig. 3 b Rated rectangular peak forward current

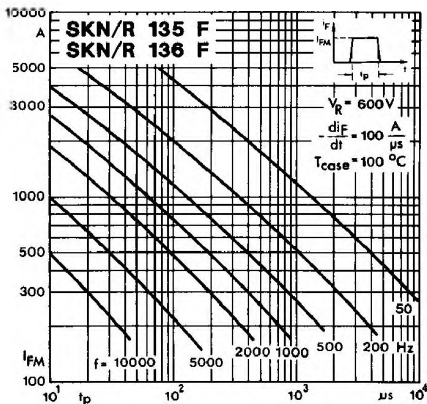

Fig. 3 c Rated rectangular peak forward current

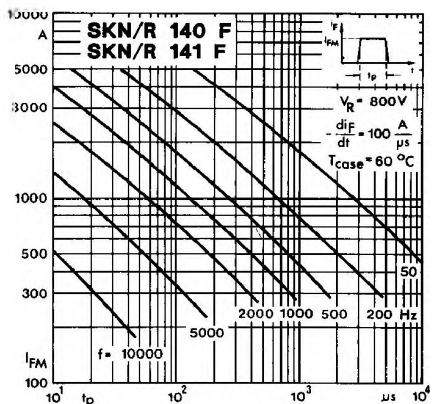

Fig. 3 d Rated rectangular peak forward current

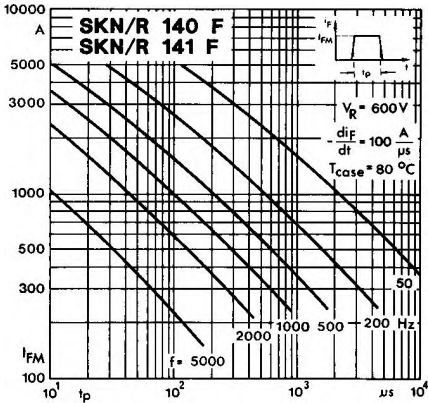

Fig. 3 e Rated rectangular peak forward current

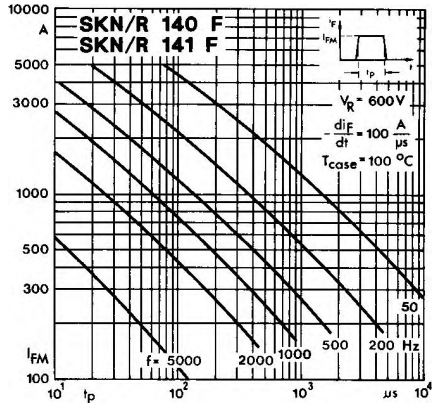

Fig. 3 f Rated rectangular peak forward current

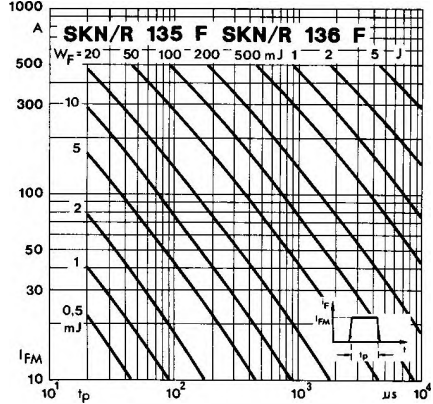

Fig. 4 a Forward energy dissipation, rectangular

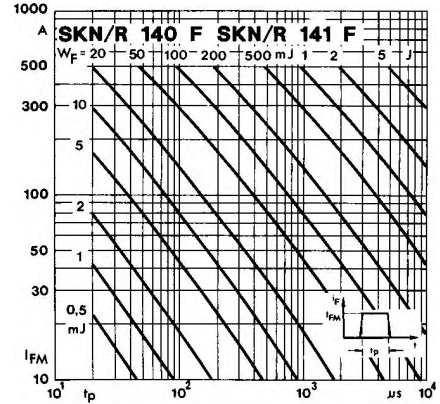

Fig. 4 b Forward energy dissipation, rectangular

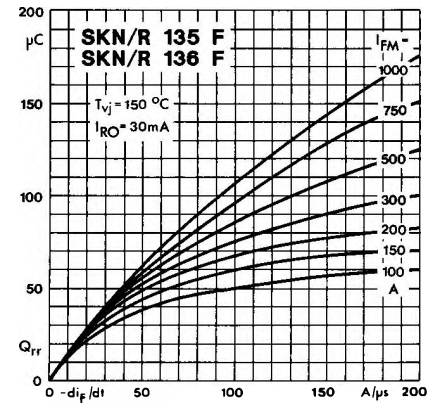

Fig. 5 a Recovered charge

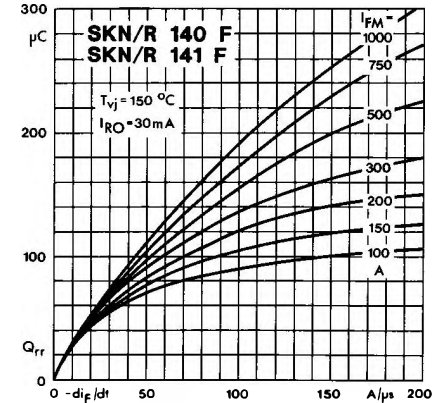

Fig. 5 b Recovered charge

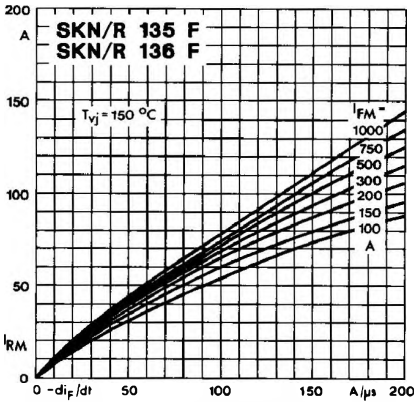

Fig. 6 a Peak reverse recovery current

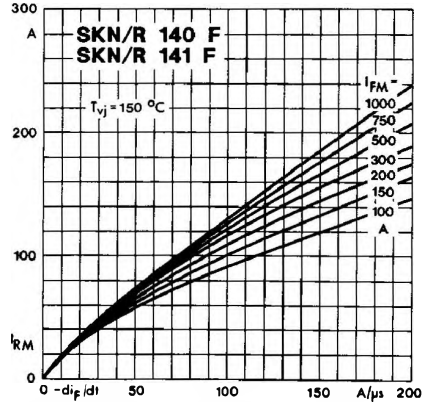

Fig. 6 b Peak reverse recovery current

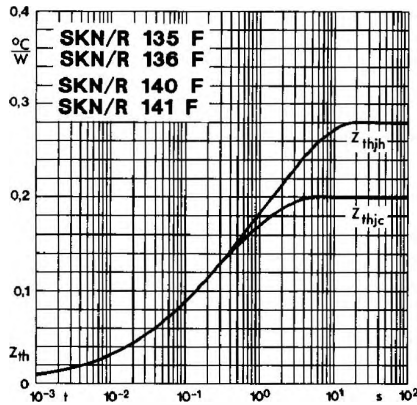

Fig. 7 Transient thermal impedance

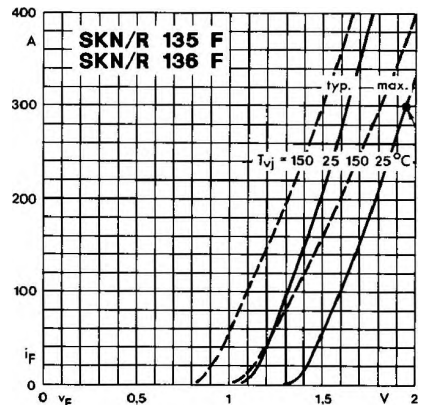

Fig. 8 a Forward characteristics

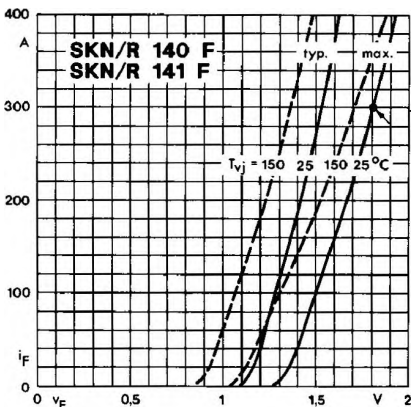

Fig. 8 b Forward characteristics

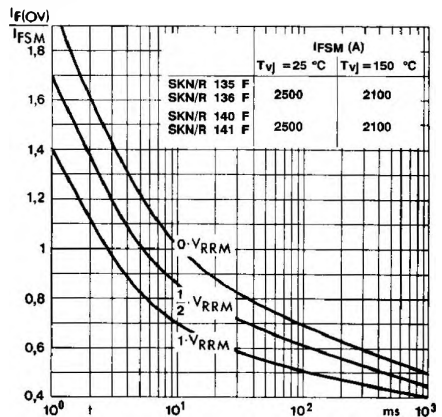
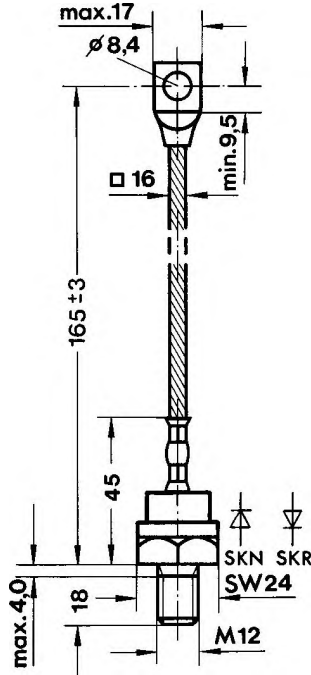

Fig. 9 Rated surge overload current

SKN 135 F
 SKR 135 F
 SKN 140 F
 SKR 140 F

Case E 14

IEC: A 9 MA¹⁾
 DIN 41 887: 105 B 2¹⁾
 BS 3934: SO-29 B
 JEDEC: DO-205 AC (DO-30)¹⁾²⁾



Dimensions in mm

SKN 136 F
 SKR 136 F
 SKN 141 F
 SKR 141 F

Case E 31

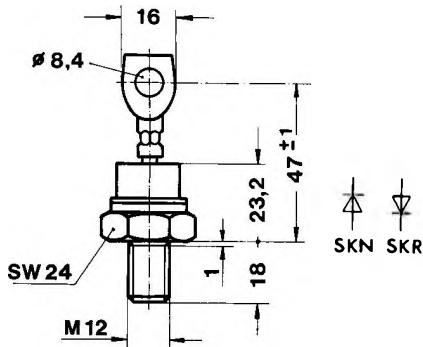

Dimensions in mm

¹⁾ modified

²⁾ These types are also available with the original DO-205 AA (DO-8) dimensions with thread 3/8-24.