

MEDIUM-SPEED SWITCH

DESCRIPTION

The 2N4036 is a silicon planar epitaxial PNP transistor in Jedec TO-39 metal case. It is intended particularly as medium speed saturated switch and general purpose amplifier.

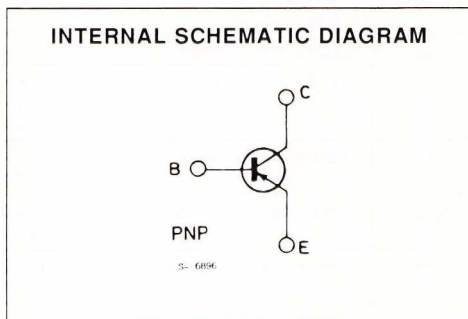
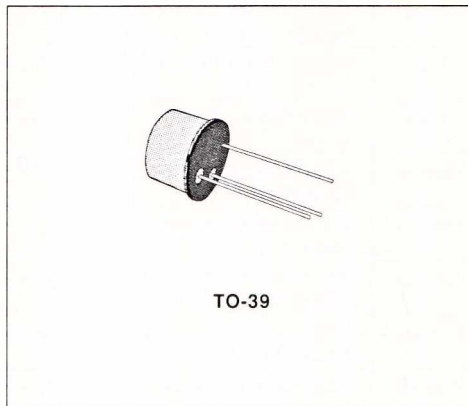

ABSOLUTE MAXIMUM RATINGS

Symbol	Parameter	Value	Unit
V_{CBO}	Collector-base Voltage ($I_E = 0$)	- 90	V
V_{CEX}	Collector-emitter Voltage ($V_{BE} = 1.5$ V)	- 85	V
V_{CER}	Collector-emitter Voltage ($R_{BE} \leq 200 \Omega$)	- 85	V
V_{CEO}	Collector-emitter Voltage ($I_B = 0$)	- 65	V
V_{EBO}	Emitter-base Voltage ($I_C = 0$)	- 6	V
I_C	Collector Current	- 1	A
I_B	Base Current	- 0.5	A
P_{Tot}	Total Power Dissipation at $T_{amb} \leq 25$ °C	1	W
	at $T_{case} \leq 25$ °C	7	W
T_{stg}, T_J	Storage and Junction Temperature	- 65 to 200	°C

THERMAL DATA

$R_{th\ j-case}$	Thermal Resistance Junction-case	Max	25	°C/W
$R_{th\ j-amb}$	Thermal Resistance Junction-ambient	Max	175	°C/W

ELECTRICAL CHARACTERISTICS ($T_{amb} = 25\text{ °C}$ unless otherwise specified)

Symbol	Parameter	Test Conditions	Min.	Typ.	Max.	Unit
I_{CBO}	Collector Cutoff Current ($I_E = 0$)	$V_{CB} = -60\text{ V}$			-20	nA
I_{CEO}	Collector Cutoff Current ($I_B = 0$)	$V_{CE} = -30\text{ V}$			-0.5	μA
I_{EBO}	Emitter Cutoff Current ($I_C = 0$)	$V_{EB} = -5\text{ V}$			-20	nA
$V_{(BR)CBO}$	Collector-base Breakdown Voltage ($I_E = 0$)	$I_C = -100\text{ μA}$	-90			V
$V_{(BR)CEX}^*$	Collector-emitter Breakdown Voltage ($V_{BE} = 1.5\text{ V}$)	$I_C = -10\text{ mA}$	-85			V
$V_{(BR)CER}^*$	Collector-emitter Breakdown Voltage ($R_{BE} = 200\text{ Ω}$)	$I_C = -10\text{ mA}$	-85			V
$V_{(BR)CEO}^*$	Collector-emitter Breakdown Voltage ($I_B = 0$)	$I_C = -10\text{ mA}$	-65			V
$V_{(BR)EBO}$	Emitter-base Breakdown Voltage ($I_C = 0$)	$I_E = -100\text{ μA}$	-7			V
$V_{CE(sat)}^*$	Collector-emitter Saturation Voltage	$I_C = -150\text{ mA}$ $I_B = -15\text{ mA}$			-0.65	V
V_{BE}^*	Base-emitter Voltage	$I_C = -150\text{ mA}$ $V_{CE} = -10\text{ V}$			-1.1	V
h_{FE}^*	DC Current Gain	$I_C = -0.1\text{ mA}$ $V_{CE} = -10\text{ V}$ $I_C = -150\text{ mA}$ $V_{CE} = -10\text{ V}$ $I_C = -500\text{ mA}$ $V_{CE} = -10\text{ V}$	20 40 20		140	
f_T	Transition Frequency	$I_C = -50\text{ mA}$ $V_{CE} = -10\text{ V}$ $f = 20\text{ MHz}$		60		MHz
C_{EBO}	Emitter-base Capacitance	$I_C = 0$ $V_{EB} = -0.5\text{ V}$ $f = 1\text{ MHz}$			90	pF
C_{CBO}	Collector-base Capacitance	$I_E = 0$ $V_{CB} = -10\text{ V}$ $f = 1\text{ MHz}$			30	pF
t_{on}^{**}	Turn-on Time	$I_C = -150\text{ mA}$ $V_{CC} = -30\text{ V}$ $I_{B1} = -15\text{ mA}$			110	ns
t_{off}^{**}	Turn-off Time	$I_C = -150\text{ mA}$ $V_{CC} = -30\text{ V}$ $I_{B1} = -I_{B2} = -15\text{ mA}$			700	ns

* Pulsed : pulse duration = 300 μs, duty cycle = 1 %.

** See test circuit.

Test Circuit for t_{on} , t_{off} .