

GENERAL PURPOSE TRANSISTORS

DESCRIPTION

The BC140 and BC141 are silicon planar epitaxial NPN transistors in TO-39 metal case. They are particularly designed for audio amplifiers and switching applications up to 1 A. The complementary PNP types are the BC160 and BC161.

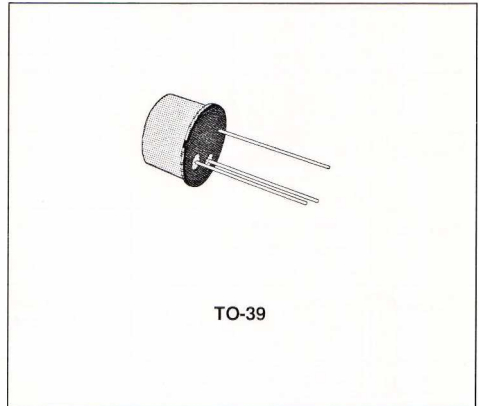

INTERNAL SCHEMATIC DIAGRAM

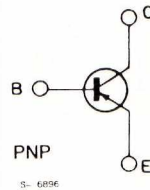
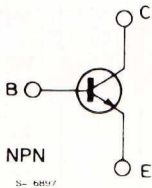

ABSOLUTE MAXIMUM RATINGS

Symbol	Parameter	Value		Unit
		BC140	BC141	
V_{CBO}	Collector-base Voltage ($I_E = 0$)	80	100	V
V_{CEO}	Collector-emitter Voltage ($I_B = 0$)	40	60	V
V_{EBO}	Emitter-base Voltage ($I_C = 0$)	7		V
I_C	Collector Current	1		A
I_B	Base Current	0.1		A
P_{tot}	Total Power Dissipation at $T_{amb} \leq 45^\circ\text{C}$ at $T_{case} \leq 45^\circ\text{C}$	0.65		W
		3.7		W
T_{stg}	Storage Temperature	- 55 to 175		$^\circ\text{C}$
T_j	Junction Temperature	175		$^\circ\text{C}$

THERMAL DATA

$R_{th\ j-case}$	Thermal Resistance Junction-case	Max	35	°C/W
$R_{th\ j-amb}$	Thermal Resistance Junction-ambient	Max	200	°C/W

ELECTRICAL CHARACTERISTICS ($T_{amb} = 25\ ^\circ\text{C}$ unless otherwise specified)

Symbol	Parameter	Test Conditions	Min.	Typ.	Max.	Unit
I_{CES}	Collector Cutoff Current ($I_E = 0$)	$V_{CES} = 60\ \text{V}$ $V_{CES} = 60\ \text{V}$ $T_{amb} = 150\ ^\circ\text{C}$			100 100	nA μA
$V_{(BR)CBO}$	Collector-base Breakdown Voltage ($I_E = 0$)	$I_C = 100\ \mu\text{A}$ for BC140 for BC141	80 100			V V
$V_{(BR)CEO}^*$	Collector-emitter Breakdown Voltage ($I_B = 0$)	$I_C = 30\ \text{mA}$ for BC140 for BC141	40 60			V V
$V_{(BR)EBO}$	Emitter-base Breakdown Voltage ($I_C = 0$)	$I_E = 100\ \mu\text{A}$	7			V
$V_{CE(sat)}^*$	Collector-emitter Saturation Voltage	$I_C = 100\ \text{mA}$ $I_B = 10\ \text{mA}$ $I_C = 500\ \text{mA}$ $I_B = 50\ \text{mA}$ $I_C = 1\ \text{A}$ $I_B = 0.1\ \text{A}$		0.1 0.35 0.6	1	V V V
V_{BE}^*	Base-emitter Voltage	$I_C = 1\ \text{A}$ $V_{CE} = 1\ \text{V}$		1.25	1.8	V
h_{FE}^*	DC Current Gain	$I_C = 100\ \mu\text{A}$ $V_{CE} = 1\ \text{V}$ for BC140-141 for BC140-141 Gr. 6 for BC140-141 Gr. 10 for BC140-141 Gr. 16 $I_C = 100\ \text{mA}$ $V_{CE} = 1\ \text{V}$ for BC140-141 for BC140-141 Gr. 6 for BC140-141 Gr.10 for BC140-141 Gr.16 $I_C = 1\ \text{A}$ $V_{CE} = 1\ \text{V}$ for BC140-141 for BC140-141 Gr. 6 for BC140-141 Gr.10 for BC140-141 Gr.16		75 28 40 90 40 40 63 100 100 26 15 20 30	140 63 100 160 250 100 160 250	
f_T	Transition Frequency	$I_C = 50\ \text{mA}$ $V_{CE} = 10\ \text{V}$	50			MHz
C_{CBO}	Collector-base Capacitance	$I_E = 0$ $V_{CB} = 10\ \text{V}$ $f = 1\ \text{MHz}$		12	25	pF
t_{on}	Turn-on Time	$I_C = 100\ \text{mA}$ $I_{B1} = 5\ \text{mA}$			250	ns
t_{off}	Turn-off Time	$I_C = 100\ \text{mA}$ $I_{B1} = I_{B2} = 5\ \text{mA}$			850	ns

* Pused : pulse duration = 300 μs , duty cycle = 1 %.

Collector-emitter Saturation Voltage.

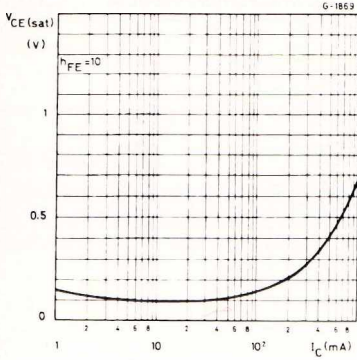

Base-emitter Voltage.

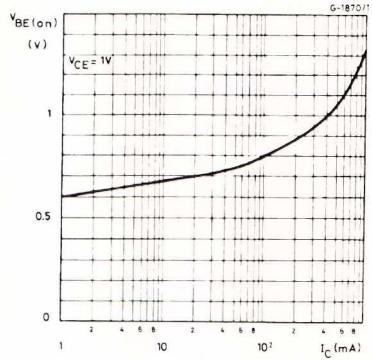

DC Current Gain.

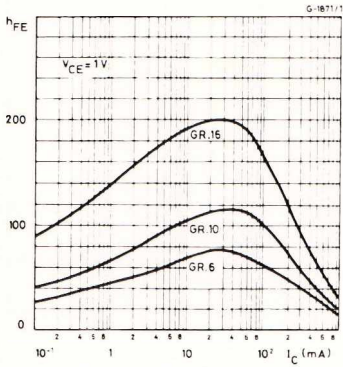

Transition Frequency.

