

WIDE BAND VHF/UHF AMPLIFIER

- SILICON PLANAR EPITAXIAL TRANSISTOR
- TO-72 METAL CASE
- VERY LOW NOISE

APPLICATIONS :

- TELECOMMUNICATIONS
- WIDE BAND UHF AMPLIFIER
- RADIO COMMUNICATIONS

DESCRIPTION

The BRF99A is a silicon planar epitaxial PNP transistor produced using interdigitated base emitter geometry. It is particularly designed for use in wide band common-emitter linear amplifiers up to 1GHz. It features very high f_t , low reverse capacitance, excellent cross modulation properties and very low noise performance. The BRF99A is complementary to the BFY90. Typical applications include telecommunication and radio communication equipment.

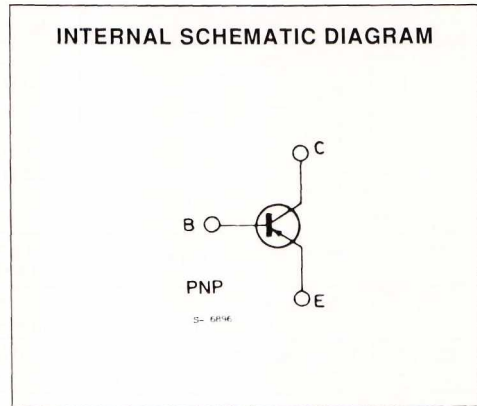
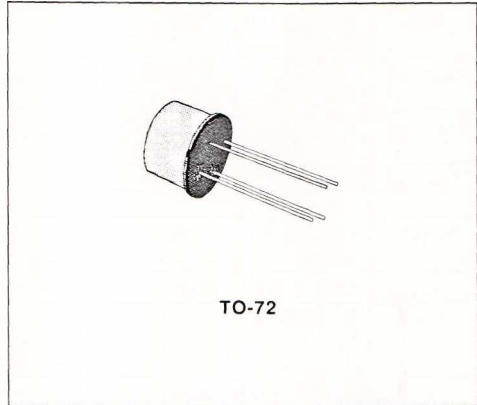

ABSOLUTE MAXIMUM RATINGS

Symbol	Parameter	Value	Unit
V_{CBO}	Collector-base Voltage ($I_E = 0$)	- 25	V
V_{CEO}	Collector-emitter Voltage ($I_B = 0$)	- 25	V
V_{EBO}	Emitter-base Voltage ($I_C = 0$)	- 3	V
I_C	Collector Current	- 50	mA
P_{tot}	Total Power Dissipation at $T_{amb} \leq 25^\circ C$ at $T_{case} \leq 25^\circ C$	225	mW
		360	mW
T_{stg}, T_j	Storage and Junction Temperature	- 55 to 200	$^\circ C$

THERMAL DATA

$R_{th\ j-case}$	Thermal Resistance Junction–case	Max	486	°C/W
$R_{th\ j-amb}$	Thermal Resistance Junction–ambient	Max	777	°C/W

ELECTRICAL CHARACTERISTICS ($T_{amb} = 25\text{ °C}$ unless otherwise specified)

Symbol	Parameter	Test Conditions	Min.	Typ.	Max.	Unit
I_{CBO}	Collector Cutoff Current ($I_E = 0$)	$V_{CB} = -15\text{ V}$			-100	nA
$V_{(BR)\ CBO}$	Collector–base Breakdown Voltage ($I_E = 0$)	$I_C = -100\ \mu\text{A}$	-25			V
$V_{CE0\ (sus)^*}$	Collector–emitter Sustaining Voltage ($I_B = 0$)	$I_C = -5\text{ mA}$	-25			V
$V_{(BR)\ EBO}$	Emitter–base Breakdown Voltage ($I_C = 0$)	$I_E = -10\ \mu\text{A}$	-3			V
V_{CEK}^{**}	Collector–emitter Knee Voltage	$I_C = -20\text{ mA}$		-0.8		V
V_{BE}	Base–emitter Voltage	$I_C = -10\text{ mA}$ $V_{CE} = -10\text{ V}$		-0.75		V
h_{FE}^*	DC Current Gain	$I_C = -1\text{ mA}$ $V_{CE} = -10\text{ V}$ $I_C = -10\text{ mA}$ $V_{CE} = -10\text{ V}$ $I_C = -20\text{ mA}$ $V_{CE} = -10\text{ V}$	25	75 80		
f_T	Transition Frequency	$I_C = -10\text{ mA}$ $V_{CE} = -15\text{ V}$ $f = 100\text{ MHz}$	1.4	2.3		GHz
C_{re}	Reverse Capacitance	$I_C = 0$ $V_{CE} = -15\text{ V}$ $f = 1\text{ MHz}$		0.4		pF
NF	Noise Figure	$I_C = -3\text{ mA}$ $V_{CE} = -15\text{ V}$ $R_g = 50\ \Omega$ $I_C = -10\text{ mA}$ $V_{CE} = -15\text{ V}$ $R_g = 50\ \Omega$		2.5 3.5	4 5	dB dB
G_{pe}	Power Gain	$I_C = -10\text{ mA}$ $V_{CE} = -15\text{ V}$ $f = 800\text{ MHz}$		10		dB
P_o	Output Power	$I_C = -10\text{ mA}$ $V_{CE} = -15\text{ V}$ $f = 800\text{ MHz}$		14		mW
$ S_{21e} ^2$	Transducer Power Gain	$I_C = -10\text{ mA}$ $V_{CE} = -15\text{ V}$ $R_g = R_L = 50\ \Omega$ $f = 800\text{ MHz}$		8		dB

* Pulsed : pulse duration = 300µs, duty cycle = 1%

** I_B = value corresponding to $I_C = -22\text{ mA}$ and $V_{CE} = -1\text{ V}$.

Transition Frequency.

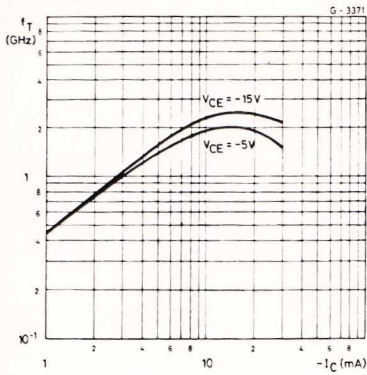

Reverse Capacitance.

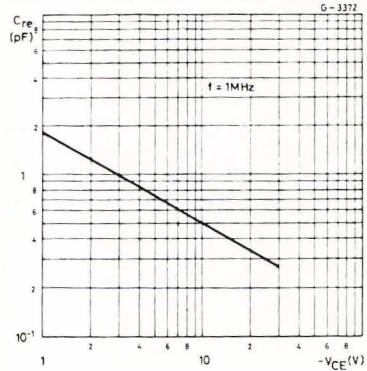

Noise Figure vs. Collector Current.

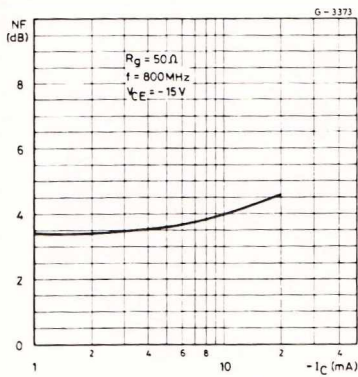

Noise Figure vs. Frequency.

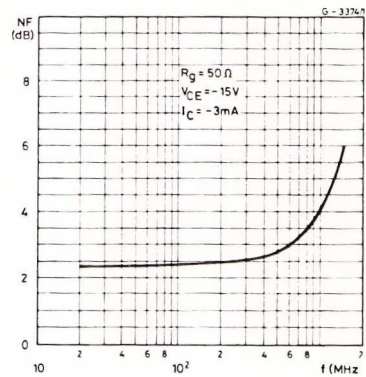

Noise Figure vs. Ambient Temperature.

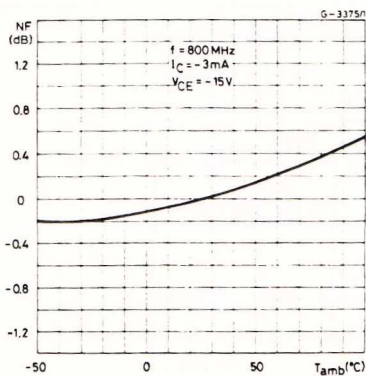

Transducer Power Gain.

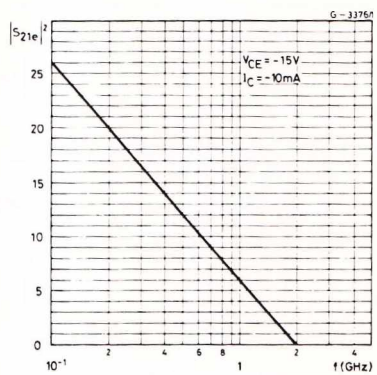

Input Impedance S_{11e} (50Ω normalized).

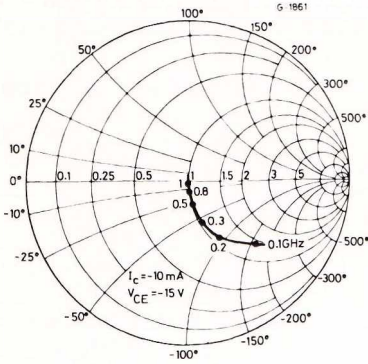

Forward Transfer Coefficient S_{21e} .

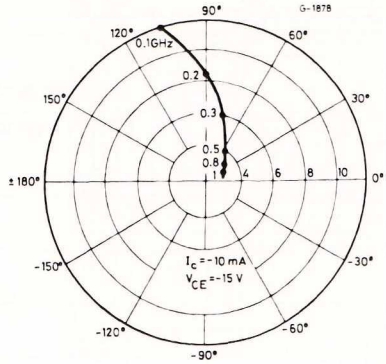

Reverse Transfer Coefficient S_{12e} .

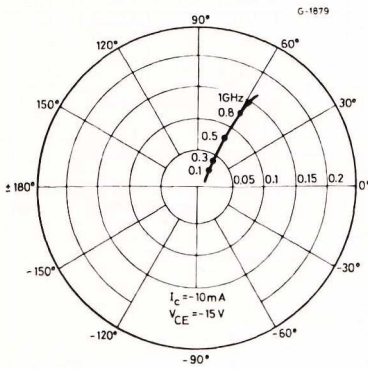

Output Impedance S_{22e} (50Ω normalized).

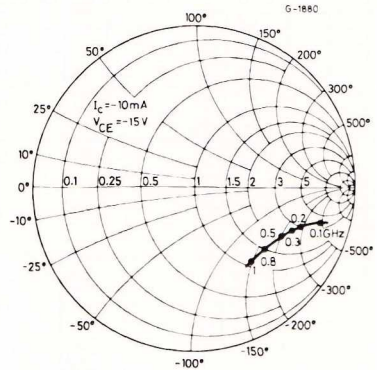

Wide Band MATV Amplifier.

