

HIGH CURRENT, GENERAL PURPOSE TRANSISTOR

DESCRIPTION

The BSS44 is a silicon epitaxial planar PNP transistor in Jedec TO-39 metal case. It is used for high-current switching and power amplifier applications up to 5A.

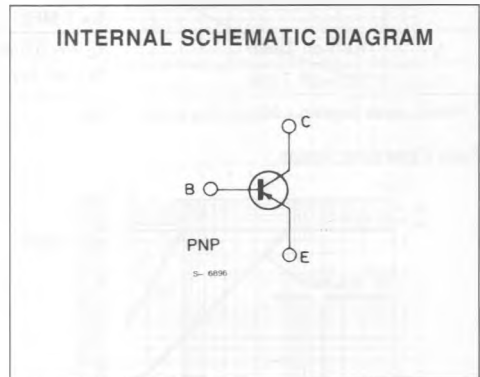
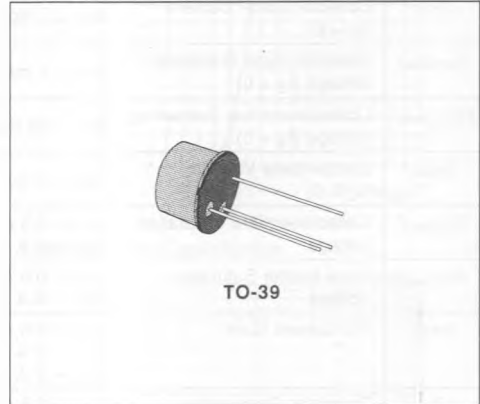

ABSOLUTE MAXIMUM RATINGS

Symbol	Parameter	Value	Unit
V_{CBO}	Collector-base Voltage ($I_E = 0$)	- 65	V
V_{CEO}	Collector-emitter Voltage ($I_B = 0$)	- 60	V
V_{EBO}	Emitter-base Voltage ($I_C = 0$)	- 6	V
I_C	Collector Current	- 5	A
P_{tot}	Total Power Dissipation at $T_{amb} \leq 25\text{ }^\circ\text{C}$ $T_{case} \leq 25\text{ }^\circ\text{C}$	0.87	W
		5	W
T_{stg}	Storage Temperature	- 65 to 200	$^\circ\text{C}$
T_j	Junction Temperature	200	$^\circ\text{C}$

THERMAL DATA

$R_{th(j-case)}$	Thermal Resistance Junction-case	Max	35	$^{\circ}C/W$
$R_{th(j-amb)}$	Thermal Resistance Junction-ambient	Max	200	$^{\circ}C/W$

ELECTRICAL CHARACTERISTICS ($T_{case} = 25^{\circ}C$ unless otherwise specified)

Symbol	Parameter	Test Conditions		Min.	Typ.	Max.	Unit
I_{CES}	Collector Cutoff Current ($I_E = 0$)	$V_{CE} = -60 V$				-0.5	μA
$V_{(BR)CBO}$	Collector-base Breakdown Voltage ($I_E = 0$)	$I_C = -1 mA$		-65			V
$V_{CE0(sus)}^*$	Collector-emitter Sustaining Voltage ($I_B = 0$)	$I_C = -50 mA$		-60			V
V_{EBO}^*	Emitter-base Voltage ($I_C = 0$)	$I_E = -1 mA$		-6			V
$V_{CE(sat)}^*$	Collector-emitter Saturation Voltage	$I_C = -0.5 A$ $I_C = -5 A$	$I_B = -50 mA$ $I_B = -0.5 A$		-0.1 -0.4		V V
$V_{BE(sat)}^*$	Base-emitter Saturation Voltage	$I_C = -0.5 A$ $I_C = -5 A$	$I_B = -50 mA$ $I_B = -0.5 mA$		-0.8 -1.1		V V
h_{FE}^*	DC Current Gain	$I_C = -0.5 A$ $I_C = -2 A$ $I_C = -5 A$	$V_{CE} = -2 V$ $V_{CE} = -2 V$ $V_{CE} = -2 V$	30 40	70 45		
f_T	Transition Frequency	$I_C = -0.5 A$	$V_{CE} = -5 V$		80		MHz
C_{CBO}	Collector-base Capacitance	$I_E = 0$ $f = 1 MHz$	$V_{CB} = -10 V$			100	pF
t_{on}	Turn-on Time	$I_C = -0.5 A$	$V_{CC} = -20 V$		0.065		μs
t_{off}	Turn-off Time	$I_{B1} = -I_{B2}$	$= -50 mA$		0.45		μs

* Pulsed : pulse duration = 300 μs , duty cycle = 1.5 %.

Safe Operating Areas.

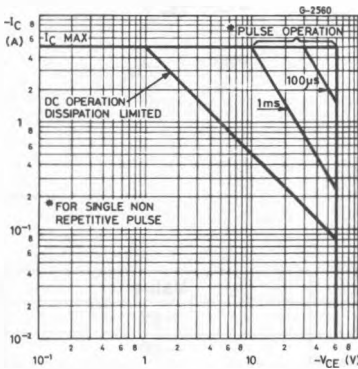

DC Current Gain.

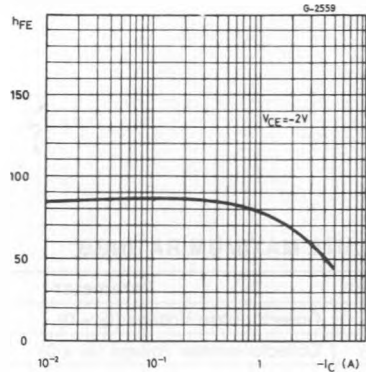

Collector-emitter Saturation Voltage.

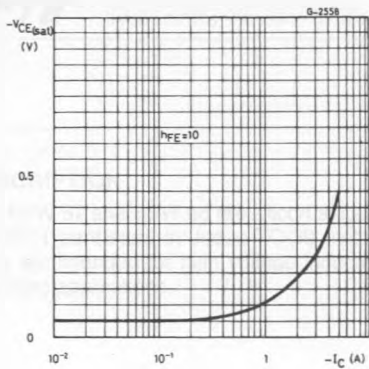

Base-emitter Saturation Voltage.

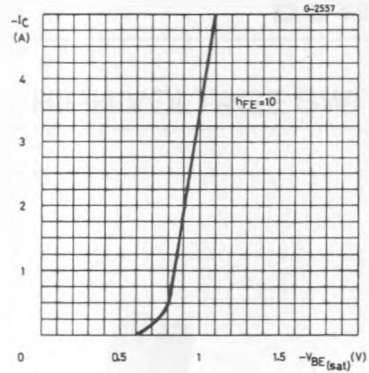

Transition Frequency.

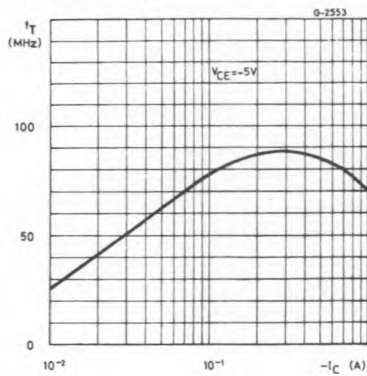

Collector-base Capacitance.

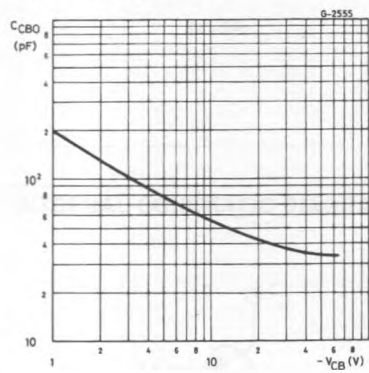

Saturated Switching Characteristics.

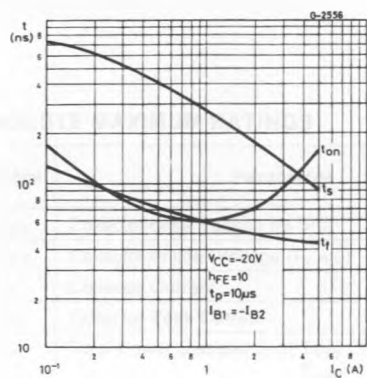

Power Rating Chart.

