

- N channel
- Enhancement mode
- Avalanche-rated

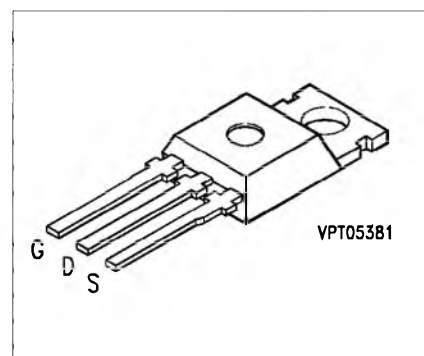

Type	$V_{DS}$	$I_D$	$R_{DS(on)}$	Package <sup>1)</sup>	Ordering Code
<b>BUZ 21</b>	100 V	21 A	0.085 $\Omega$	TO-220 AB	C67078-S1308-A2

### Maximum Ratings

Parameter	Symbol	Values	Unit
Continuous drain current, $T_C = 25\text{ }^\circ\text{C}$	$I_D$	<b>21</b>	A
Pulsed drain current, $T_C = 25\text{ }^\circ\text{C}$	$I_{D\text{ puls}}$	<b>84</b>	
Avalanche current, limited by $T_{j\text{ max}}$	$I_{AR}$	<b>21</b>	
Avalanche energy, periodic limited by $T_{j\text{ (max)}}$	$E_{AR}$	<b>11</b>	mJ
Avalanche energy, single pulse $I_D = 21\text{ A}$ , $V_{DD} = 25\text{ V}$ , $R_{GS} = 25\text{ }\Omega$ $L = 340\text{ }\mu\text{H}$ , $T_j = 25\text{ }^\circ\text{C}$	$E_{AS}$	<b>100</b>	
Gate-source voltage	$V_{GS}$	$\pm 20$	V
Power dissipation, $T_C = 25\text{ }^\circ\text{C}$	$P_{tot}$	<b>75</b>	W
Operating and storage temperature range	$T_j, T_{stg}$	<b>- 55 ... + 150</b>	$^\circ\text{C}$
Thermal resistance, chip-case	$R_{th\text{ JC}}$	$\leq 1.67$	K/W
DIN humidity category, DIN 40 040		<b>E</b>	-
IEC climatic category, DIN IEC 68-1		<b>55/150/56</b>	

1) See chapter Package Outlines.

## Electrical Characteristics

at  $T_j = 25\text{ °C}$ , unless otherwise specified.

Parameter	Symbol	Values			Unit
		min.	typ.	max.	

### Static characteristics

Drain-source breakdown voltage $V_{GS} = 0\text{ V}$ , $I_D = 0.25\text{ mA}$	$V_{(BR)DSS}$	100	–	–	V
Gate threshold voltage $V_{GS} = V_{DS}$ , $I_D = 1\text{ mA}$	$V_{GS(th)}$	2.1	3.0	4.0	
Zero gate voltage drain current $V_{DS} = 100\text{ V}$ , $V_{GS} = 0\text{ V}$ $T_j = 25\text{ °C}$ $T_j = 125\text{ °C}$	$I_{DSS}$	–	0.1 10	1.0 100	$\mu\text{A}$
Gate-source leakage current $V_{GS} = 20\text{ V}$ , $V_{DS} = 0\text{ V}$	$I_{GSS}$	–	10	100	nA
Drain-source on-resistance $V_{GS} = 10\text{ V}$ , $I_D = 13\text{ A}$	$R_{DS(on)}$	–	0.065	0.085	$\Omega$

### Dynamic characteristics

Forward transconductance $V_{DS} \geq 2 \times I_D \times R_{DS(on)max}$ , $I_D = 13\text{ A}$	$g_{fs}$	8	11	–	S
Input capacitance $V_{GS} = 0\text{ V}$ , $V_{DS} = 25\text{ V}$ , $f = 1\text{ MHz}$	$C_{iss}$	–	1000	1300	pF
Output capacitance $V_{GS} = 0\text{ V}$ , $V_{DS} = 25\text{ V}$ , $f = 1\text{ MHz}$	$C_{oss}$	–	300	530	
Reverse transfer capacitance $V_{GS} = 0\text{ V}$ , $V_{DS} = 25\text{ V}$ , $f = 1\text{ MHz}$	$C_{rss}$	–	150	240	
Turn-on time $t_{on}$ , ( $t_{on} = t_{d(on)} + t_r$ ) $V_{DD} = 30\text{ V}$ , $V_{GS} = 10\text{ V}$ , $I_D = 3\text{ A}$ , $R_{GS} = 50\text{ }\Omega$	$t_{d(on)}$	–	25	40	ns
	$t_r$	–	50	75	
Turn-off time $t_{off}$ , ( $t_{off} = t_{d(off)} + t_f$ ) $V_{DD} = 30\text{ V}$ , $V_{GS} = 10\text{ V}$ , $I_D = 3\text{ A}$ , $R_{GS} = 50\text{ }\Omega$	$t_{d(off)}$	–	160	210	
	$t_f$	–	80	110	

**Electrical Characteristics** (cont'd)  
at  $T_j = 25\text{ °C}$ , unless otherwise specified.

Parameter	Symbol	Values			Unit
		min.	typ.	max.	
<b>Reverse diode</b>					
Continuous reverse drain current $T_C = 25\text{ °C}$	$I_S$	–	–	21	A
Pulsed reverse drain current $T_C = 25\text{ °C}$	$I_{SM}$	–	–	84	
Diode forward on-voltage $I_S = 42\text{ A}$ , $V_{GS} = 0\text{ V}$	$V_{SD}$	–	1.3	1.7	V
Reverse recovery time $V_R = 30\text{ V}$ , $I_F = I_S$ , $di_F / dt = 100\text{ A}/\mu\text{s}$	$t_{rr}$	–	150	–	ns
Reverse recovery charge $V_R = 30\text{ V}$ , $I_F = I_S$ , $di_F / dt = 100\text{ A}/\mu\text{s}$	$Q_{rr}$	–	0.48	–	$\mu\text{C}$

Characteristics at  $T_j = 25^\circ\text{C}$ , unless otherwise specified.

### Total power dissipation

$$P_{\text{tot}} = f(T_C)$$

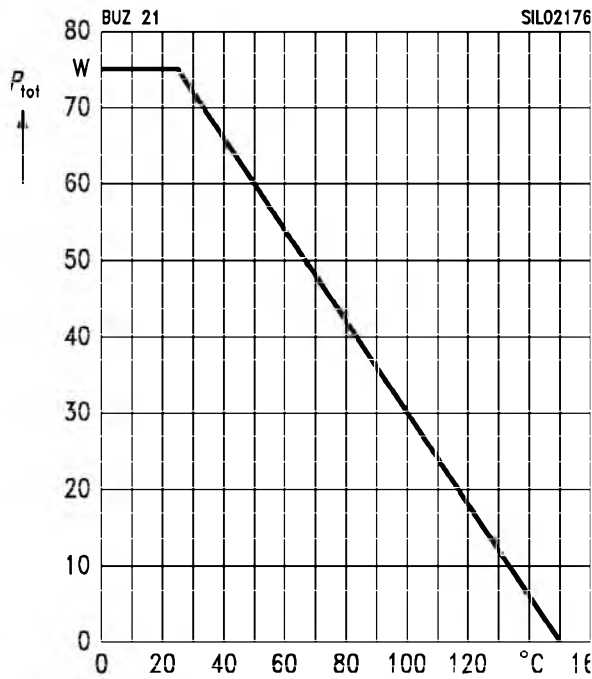

### Typ. output characteristics

$$I_D = f(V_{\text{DS}})$$

parameter:  $t_p = 80 \mu\text{s}$

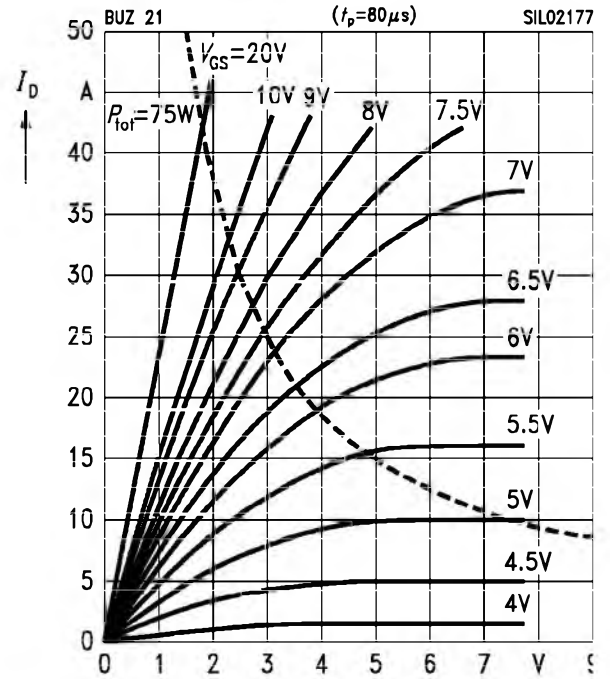

### Safe operating area

$$I_D = f(V_{\text{DS}})$$

parameter:  $D = 0.01$ ,  $T_C = 25^\circ\text{C}$

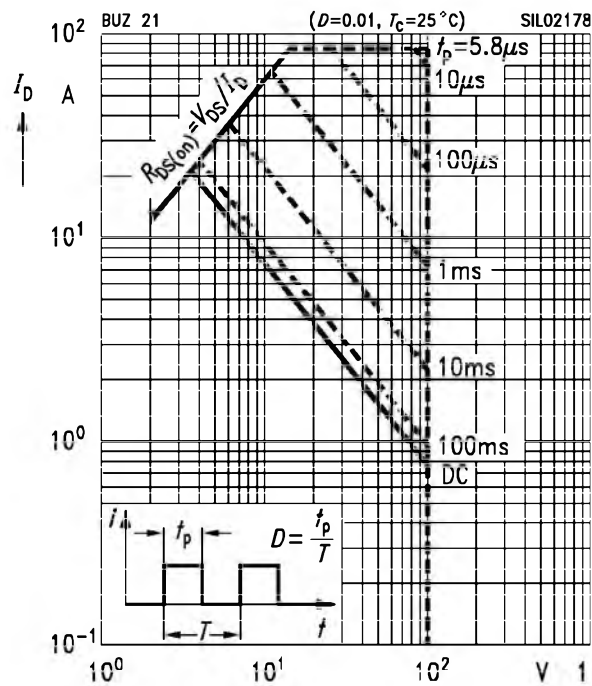

### Typ. transfer characteristics

$$I_D = f(V_{\text{GS}})$$

parameter:  $t_p = 80 \mu\text{s}$ ,  $V_{\text{DS}} = 25\text{V}$

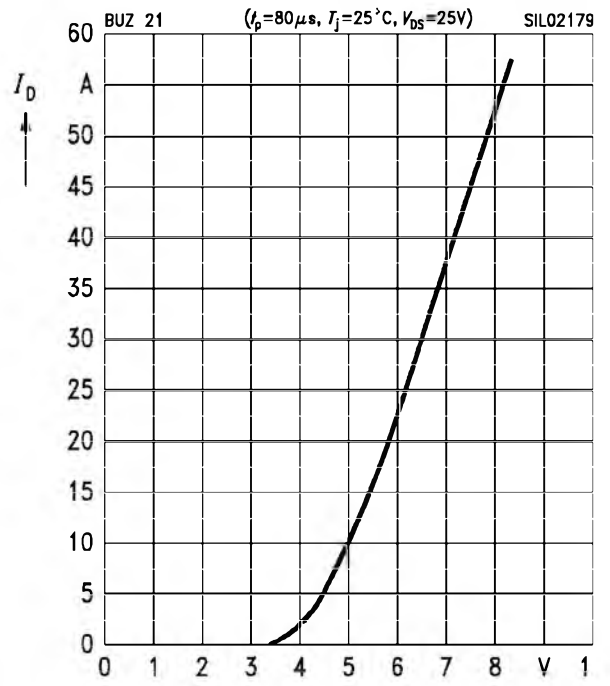

**Typ. drain-source on-resistance**

$R_{DS(on)} = f(I_D)$   
parameter:  $V_{GS}$

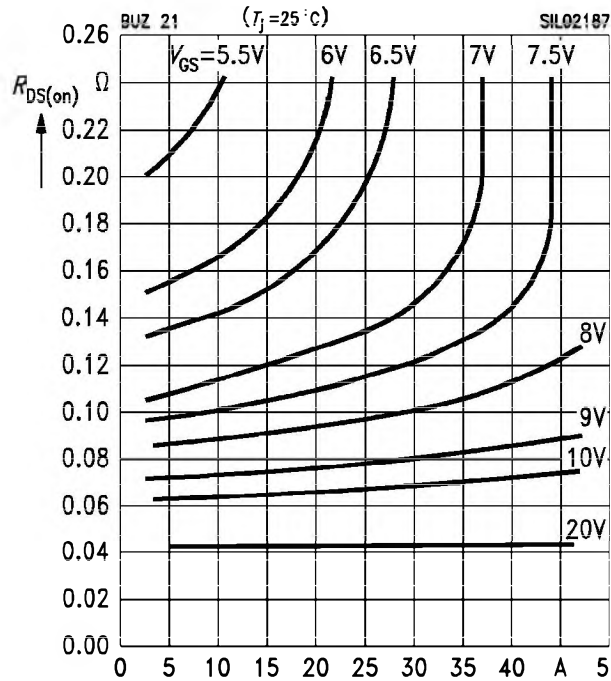

**Drain-source on-resistance**

$R_{DS(on)} = f(T_j)$   
parameter:  $I_D = 13 A, V_{GS} = 10 V, (spread)$

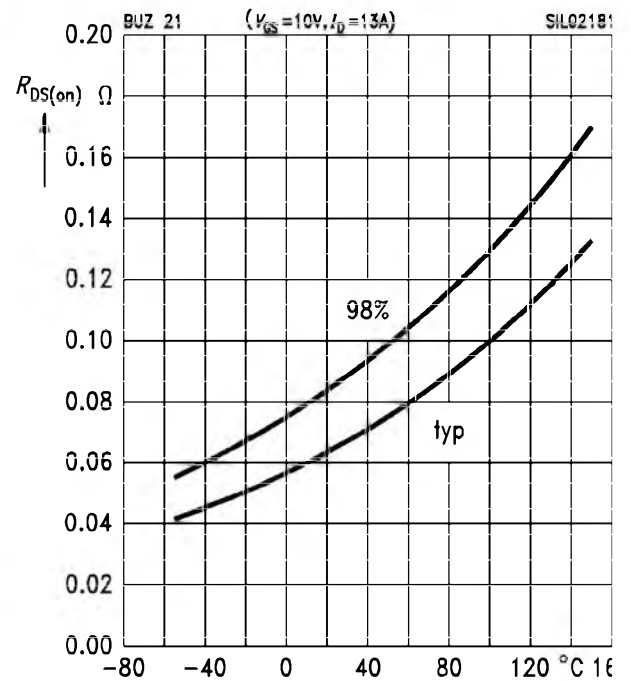

**Typ. forward transconductance**

$g_{fs} = f(I_D)$   
parameter:  $t_p = 80 \mu s$

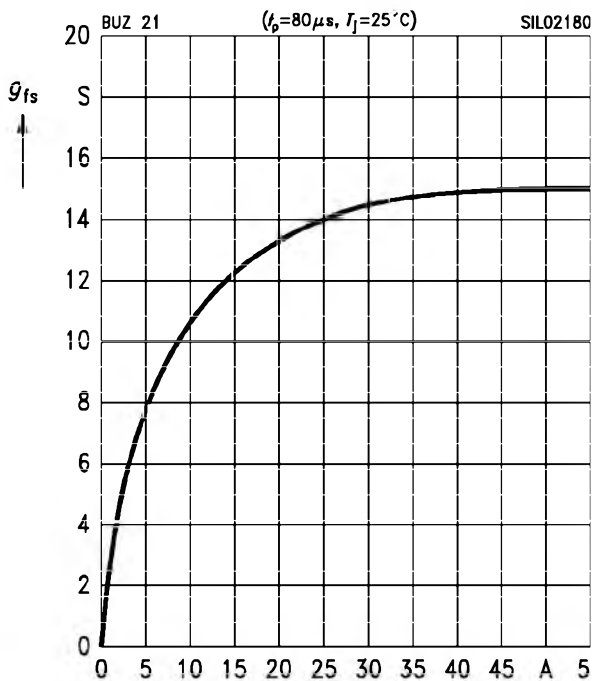

**Gate threshold voltage**

$V_{GS(th)} = f(T_j)$   
parameter:  $V_{GS} = V_{DS}, I_D = 1 mA, (spread)$

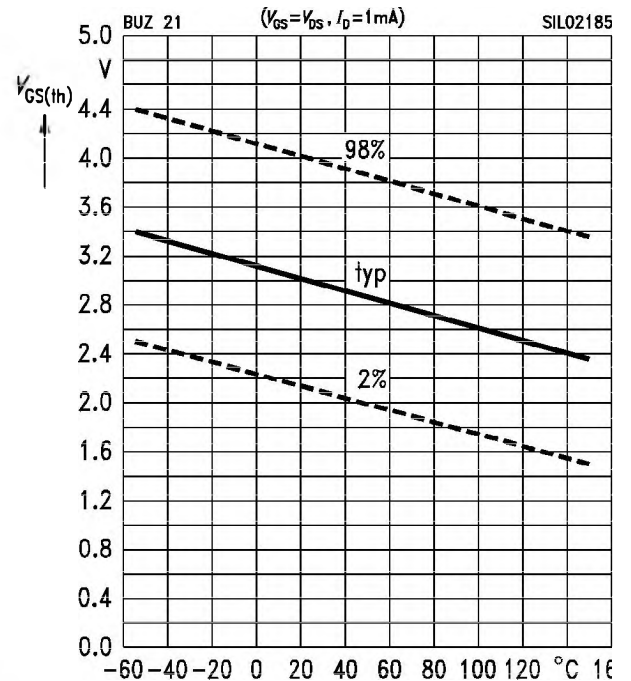

**Typ. capacitances**

$C = f(V_{DS})$

parameter:  $V_{GS} = 0\text{ V}, f = 1\text{ MHz}$

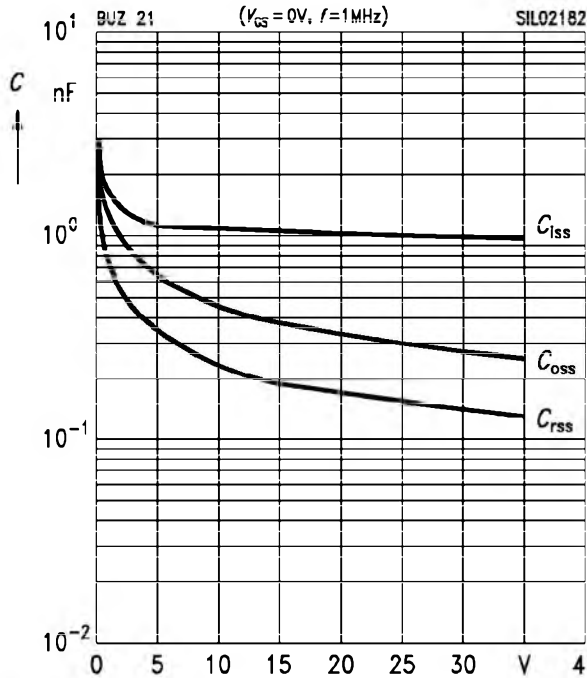

**Drain current**

$I_D = f(T_C)$

parameter:  $V_{GS} \geq 10\text{ V}$

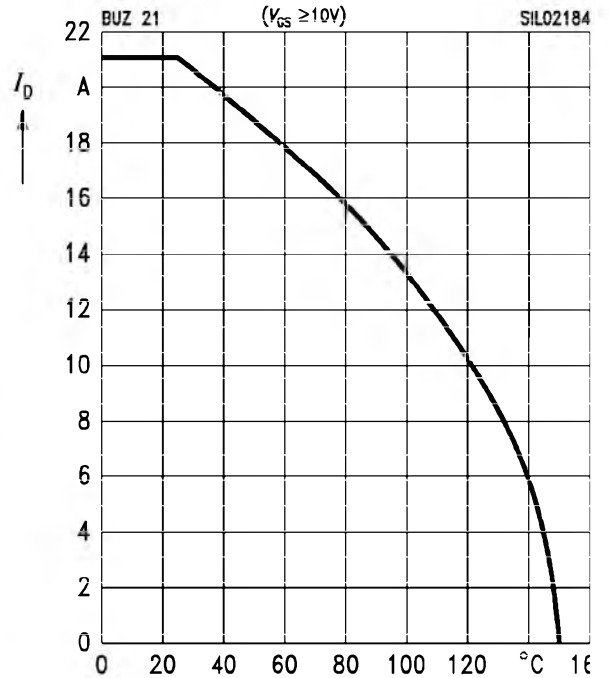

**Forward characteristics of reverse diode**

$I_F = f(V_{SD})$

parameter:  $T_i, t_p = 80\ \mu\text{s}, (spread)$

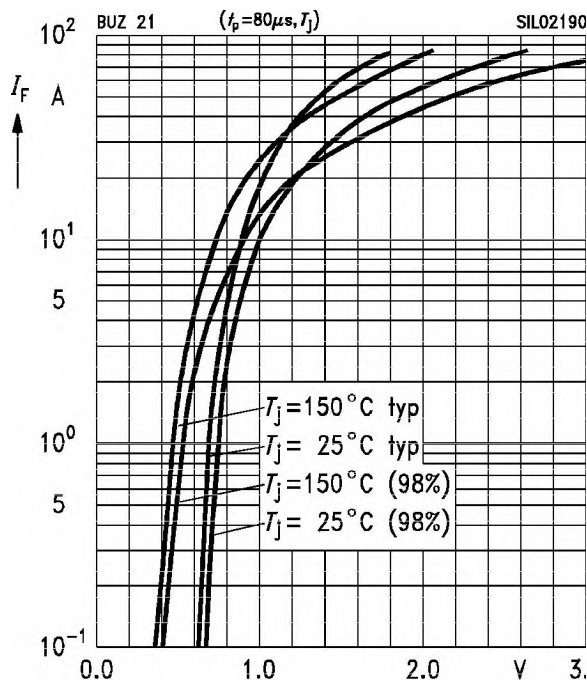

**Avalanche energy  $E_{AS} = f(T_j)$**

parameter:  $I_D = 21\text{ A}, V_{DD} = 25\text{ V}$

$R_{GS} = 25\ \Omega, L = 340\ \mu\text{H}$

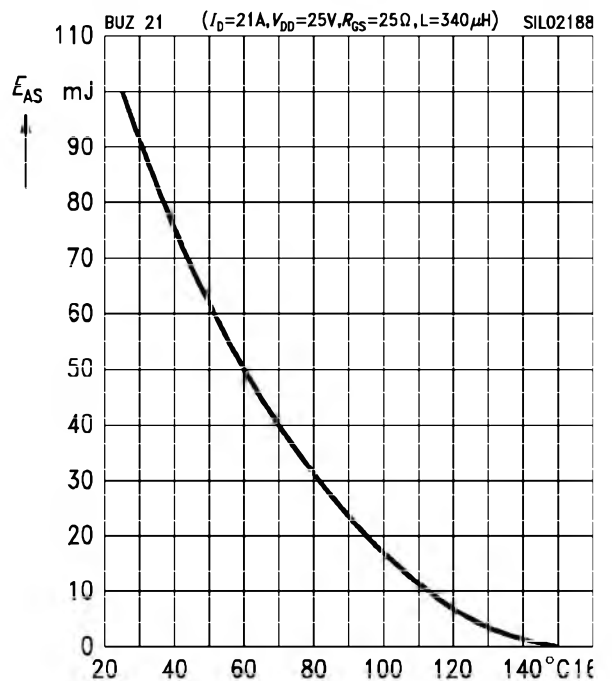

### Transient thermal impedance

$$Z_{thJC} = f(t_p)$$

parameter:  $D = t_p / T$

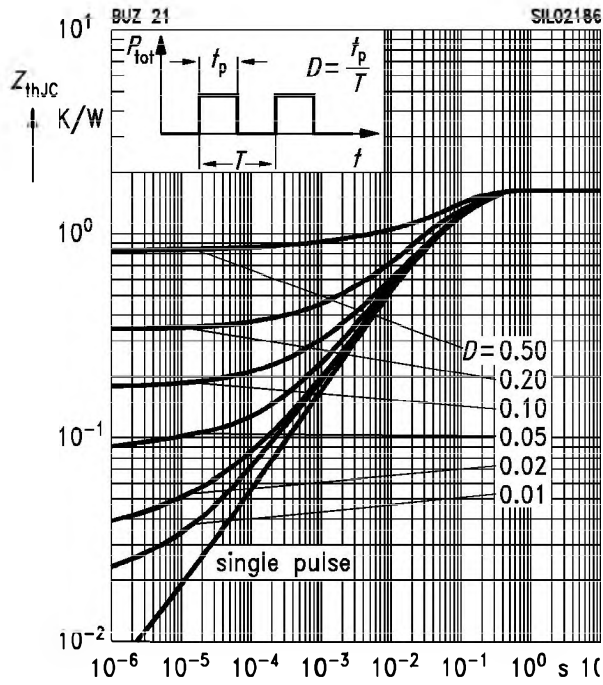

### Typ. gate charge

$$V_{GS} = f(Q_{Gate})$$

parameter:  $I_{D\ pu is} = 36.0$  A

