

SIPMOS® Power Transistors

- N channel
- Enhancement mode

BUZ 50 A BUZ 50 B, BUZ 50 C

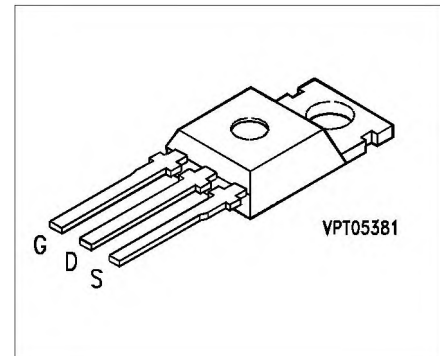

Type	V_{DS}	I_D	$R_{DS(on)}$	Package ¹⁾	Ordering Code
BUZ 50 A	1000 V	2.5 A	5.0 Ω	TO-220 AB	C67078-A1307-A3
BUZ 50 B	1000 V	2.0 A	8.0 Ω	TO-220 AB	C67078-A1307-A4
BUZ 50 C	1000 V	2.3 A	6.0 Ω	TO-220 AB	C67078-A1307-A5

Maximum Ratings

Parameter	Symbol	BUZ			Unit
		50 A	50 B	50 C	
Continuous drain current $T_C = 25\text{ °C}$	I_D	2.5	2.0	2.3	A
Pulsed drain current, $T_C = 25\text{ °C}$	$I_{D\text{ puls}}$	10.0	8.0	9.0	
Drain-source voltage	V_{DS}	1000			V
Drain-gate voltage, $R_{GS} = 20\text{ k}\Omega$	V_{DGR}	1000			
Gate-source voltage	V_{GS}	± 20			
Power dissipation, $T_C = 25\text{ °C}$	P_{tot}	75			W
Operating and storage temperature range	T_j, T_{stg}	- 55 ... + 150			$^{\circ}\text{C}$
Thermal resistance, chip-case	$R_{th\text{ JC}}$	≤ 1.67			K/W
DIN humidity category, DIN 40 040		E			-
IEC climatic category, DIN IEC 68-1		55/150/56			

1) See chapter Package Outlines.

Electrical Characteristics

at $T_j = 25\text{ °C}$, unless otherwise specified.

Parameter	Symbol	Values			Unit
		min.	typ.	max.	

Static characteristics

Drain-source breakdown voltage $V_{GS} = 0\text{ V}, I_D = 0.25\text{ mA}$	$V_{(BR)DSS}$	1000	–	–	V
Gate threshold voltage $V_{GS} = V_{DS}, I_D = 1\text{ mA}$	$V_{GS(th)}$	2.1	3.0	4.0	
Zero gate voltage drain current $V_{DS} = 1000\text{ V}, V_{GS} = 0\text{ V}$ $T_j = 25\text{ °C}$ $T_j = 125\text{ °C}$	I_{DSS}	–	20	250	μA
Gate-source leakage current $V_{GS} = 20\text{ V}, V_{DS} = 0\text{ V}$	I_{GSS}	–	10	100	nA
Drain-source on-resistance $V_{GS} = 10\text{ V}, I_D = 1.5\text{ A}$ BUZ 50 A $I_D = 1.5\text{ A}$ BUZ 50 B $I_D = 1.5\text{ A}$ BUZ 50 C	$R_{DS(on)}$	–	4.5	5.0	Ω
		–	6.5	8.0	
		–	5.0	6.0	

Dynamic characteristics

Forward transconductance $V_{DS} \geq 2 \times I_D \times R_{DS(on)max}, I_D = 1.5\text{ A}$	g_{fs}	0.7	1.5	–	S
Input capacitance $V_{GS} = 0\text{ V}, V_{DS} = 25\text{ V}, f = 1\text{ MHz}$	C_{iss}	–	1600	2100	pF
Output capacitance $V_{GS} = 0\text{ V}, V_{DS} = 25\text{ V}, f = 1\text{ MHz}$	C_{oss}	–	70	120	
Reverse transfer capacitance $V_{GS} = 0\text{ V}, V_{DS} = 25\text{ V}, f = 1\text{ MHz}$	C_{rss}	–	30	55	
Turn-on time t_{on} , ($t_{on} = t_{d(on)} + t_r$) $V_{DD} = 30\text{ V}, V_{GS} = 10\text{ V}, I_D = 2\text{ A}, R_{GS} = 50\text{ }\Omega$	$t_{d(on)}$	–	30	45	ns
	t_r	–	40	60	
Turn-off time t_{off} , ($t_{off} = t_{d(off)} + t_f$) $V_{DD} = 30\text{ V}, V_{GS} = 10\text{ V}, I_D = 2\text{ A}, R_{GS} = 50\text{ }\Omega$	$t_{d(off)}$	–	110	140	
	t_f	–	60	80	

Electrical Characteristics (cont'd)
at $T_j = 25\text{ °C}$, unless otherwise specified.

Parameter	Symbol	Values			Unit
		min.	typ.	max.	
Reverse diode					
Continuous reverse drain current $T_C = 25\text{ °C}$	I_S				A
BUZ 50 A		–	–	2.5	
BUZ 50 B		–	–	2.0	
BUZ 50 C	–	–	2.3		
Pulsed reverse drain current $T_C = 25\text{ °C}$	I_{SM}				A
BUZ 50 A		–	–	10.0	
BUZ 50 B		–	–	8.0	
BUZ 50 C	–	–	9.0		
Diode forward on-voltage $I_S = 6\text{ A}$, $V_{GS} = 0\text{ V}$	V_{SD}	–	1.05	1.3	V
Reverse recovery time $V_R = 100\text{ V}$, $I_F = I_S$, $di_F / dt = 100\text{ A}/\mu\text{s}$	t_{rr}	–	2.0	–	ns
Reverse recovery charge $V_R = 100\text{ V}$, $I_F = I_S$, $di_F / dt = 100\text{ A}/\mu\text{s}$	Q_{rr}	–	15	–	μC

Characteristics at $T_j = 25^\circ\text{C}$, unless otherwise specified.

Total power dissipation

$$P_{\text{tot}} = f(T_C)$$

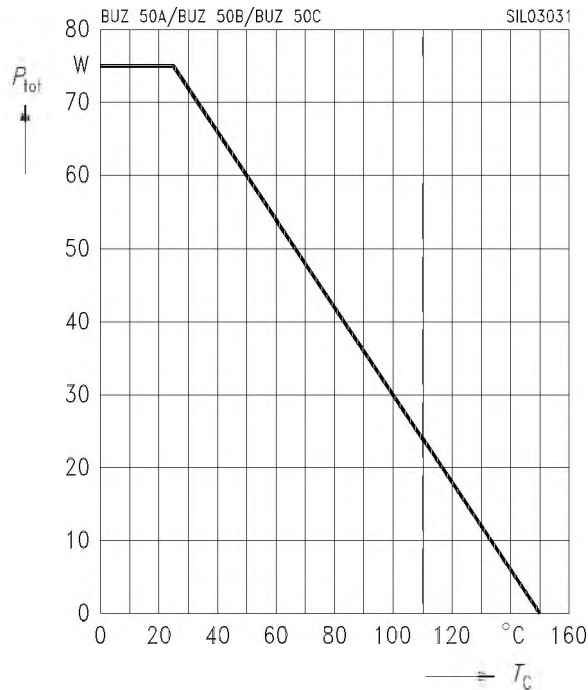

Typ. output characteristics

$$I_D = f(V_{\text{DS}})$$

parameter: $t_p = 80 \mu\text{s}$

BUZ 50 A

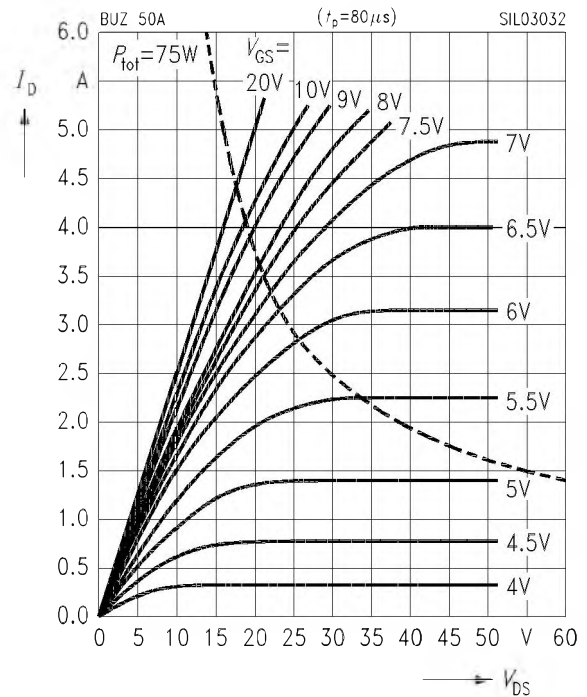

Typ. output characteristics

$$I_D = f(V_{\text{DS}})$$

parameter: $t_p = 80 \mu\text{s}$

BUZ 50 B

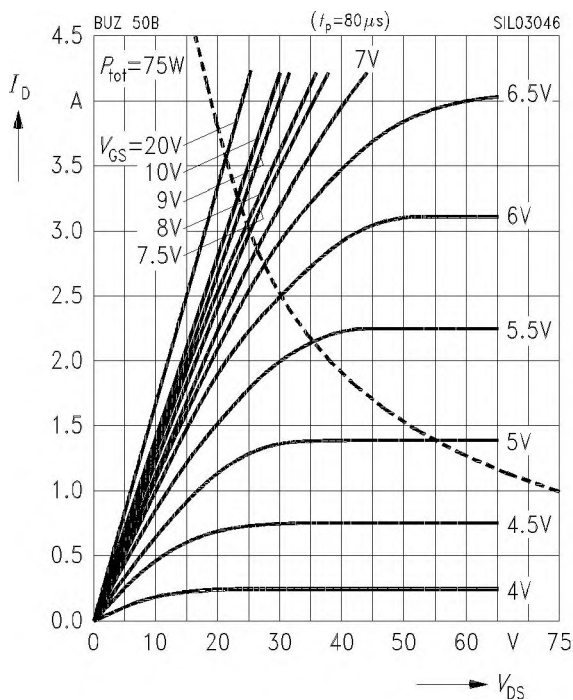

Typ. output characteristics

$$I_D = f(V_{\text{DS}})$$

parameter: $t_p = 80 \mu\text{s}$

BUZ 50 C

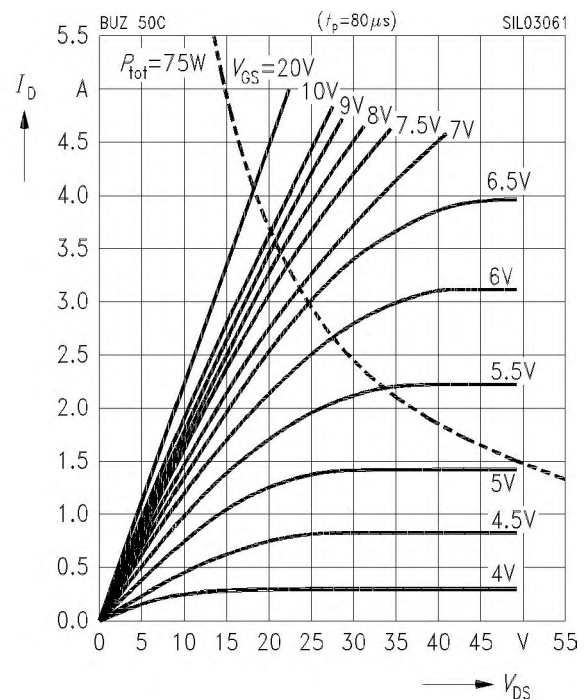

Safe operating area

$$I_D = f(V_{DS})$$

parameter: $D = 0.01$, $T_C = 25^\circ\text{C}$

BUZ 50 A

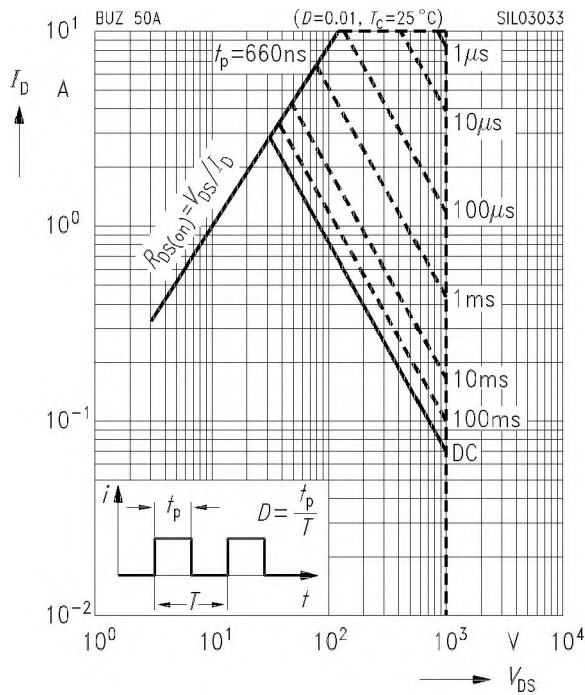

Safe operating area

$$I_D = f(V_{DS})$$

parameter: $D = 0.01$, $T_C = 25^\circ\text{C}$

BUZ 50 B

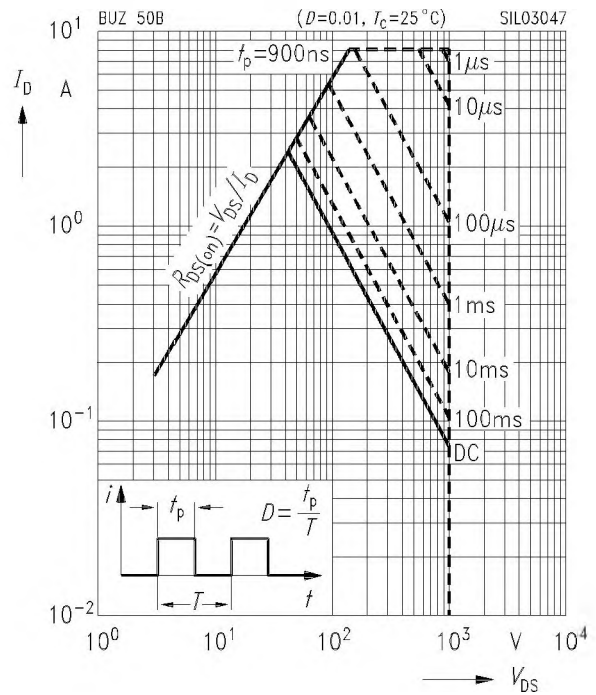

Safe operating area

$$I_D = f(V_{DS})$$

parameter: $D = 0.01$, $T_C = 25^\circ\text{C}$

BUZ 50 C

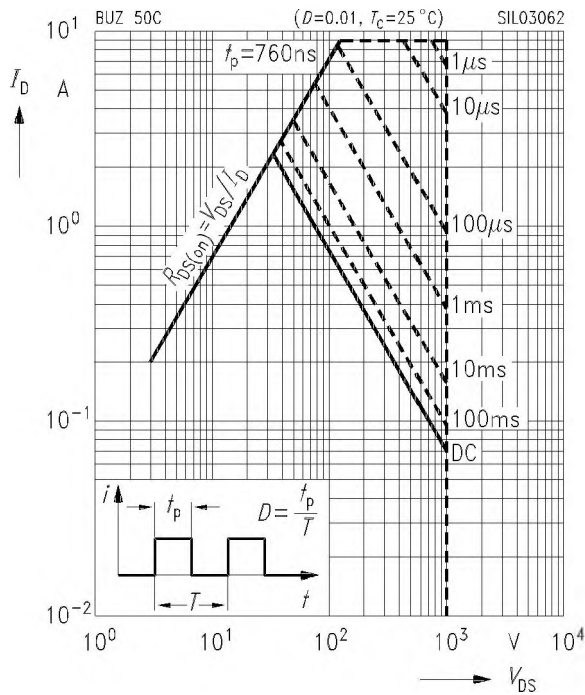

Typ. transfer characteristics

$$I_D = f(V_{GS})$$

parameter: $t_p = 80\ \mu\text{s}$, $V_{DS} = 25\ \text{V}$

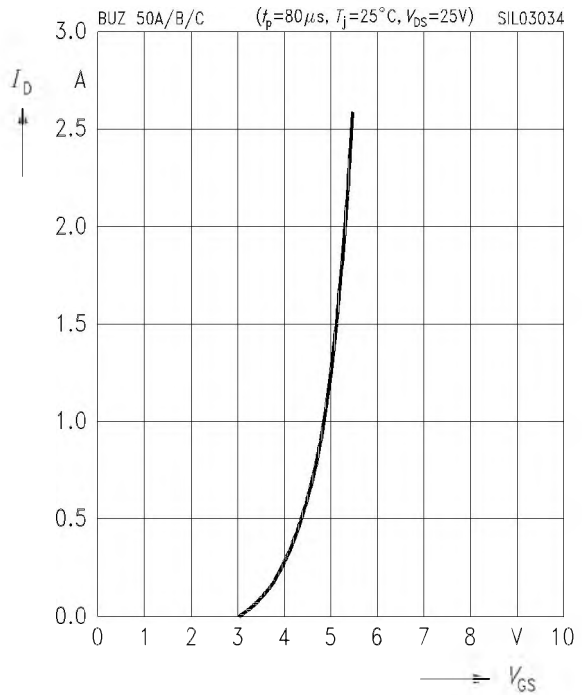

Typ. drain-source on-resistance

$$R_{DS(on)} = f(I_D)$$

parameter: V_{GS}

BUZ 50 A

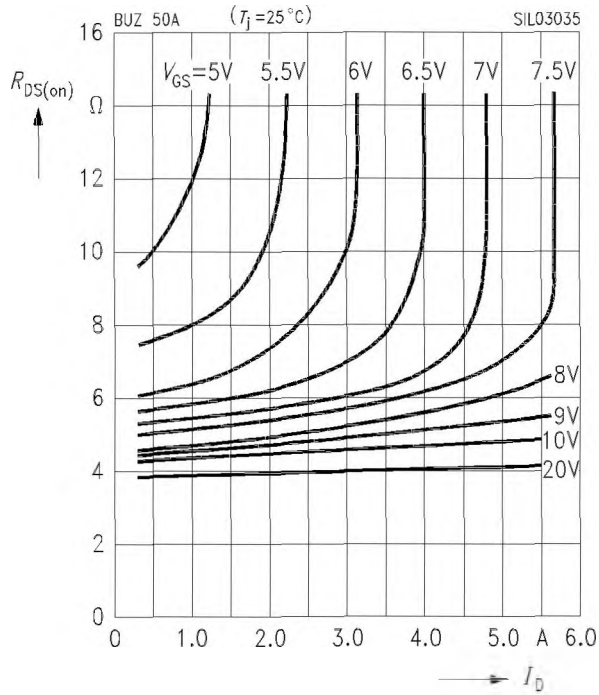

Typ. drain-source on-resistance

$$R_{DS(on)} = f(I_D)$$

parameter: V_{GS}

BUZ 50 C

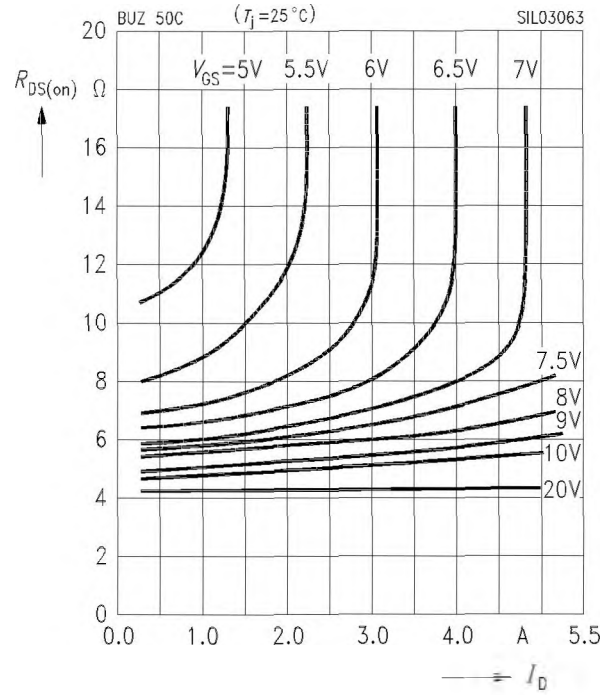

Drain-source on-resistance

$$R_{DS(on)} = f(I_D)$$

parameter: V_{GS}

BUZ 50 B

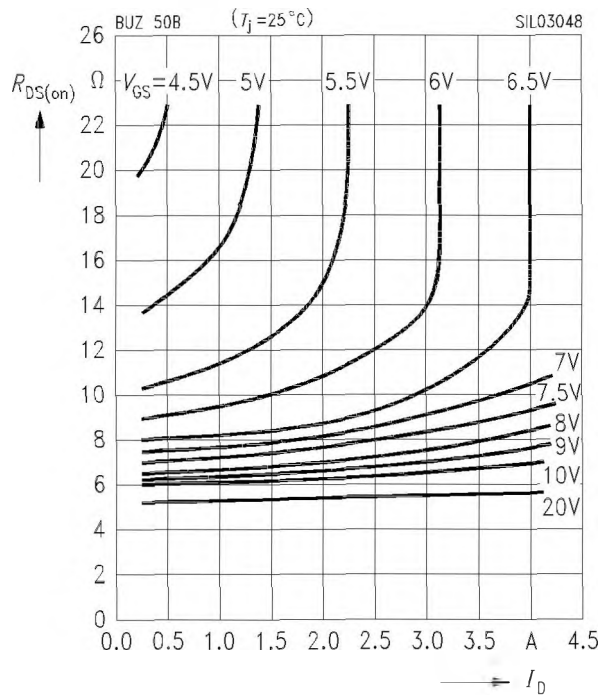

Drain-source on-resistance

$$R_{DS(on)} = f(T_j)$$

parameter: $V_{GS} = 10\text{ V}, I_D = 1.5\text{ A}$

BUZ 50 A

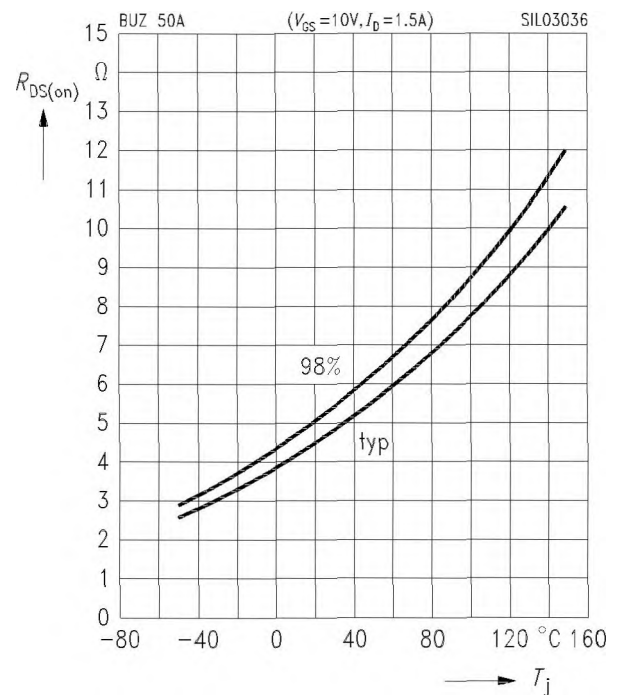

Drain-source on-resistance

$$R_{DS(on)} = f(T_j)$$

BUZ 50 B

parameter: $V_{GS} = 10\text{ V}$, $I_D = 1.5\text{ A}$

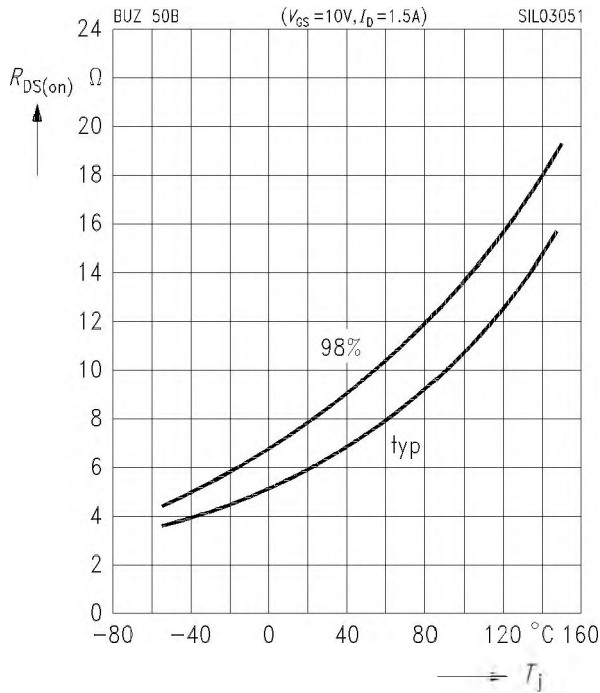

Drain-source on-resistance

$$R_{DS(on)} = f(T_j)$$

BUZ 50 C

parameter: $V_{GS} = 10\text{ V}$, $I_D = 1.5\text{ A}$

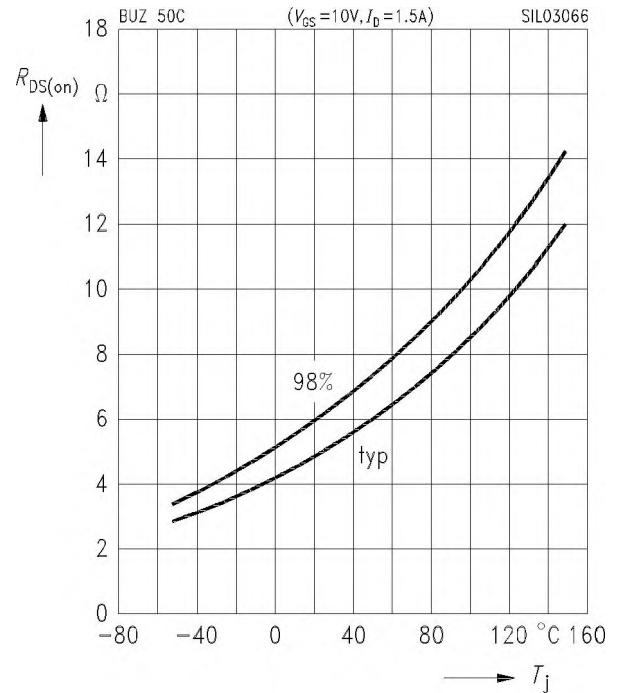

Typ. forward transconductance

$$g_{fs} = f(I_D)$$

parameter: $t_p = 80\ \mu\text{s}$

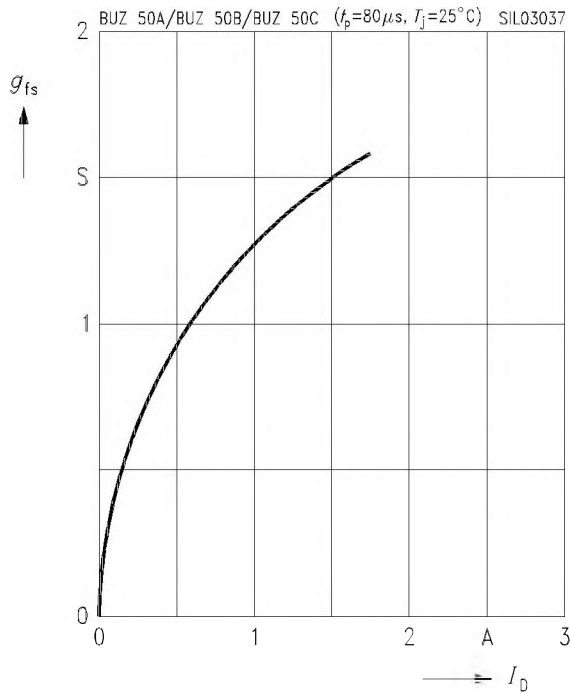

Gate threshold voltage

$$V_{GS(th)} = f(T_j)$$

parameter: $V_{GS} = V_{DS}$, $I_D = 1\text{ mA}$, (spread)

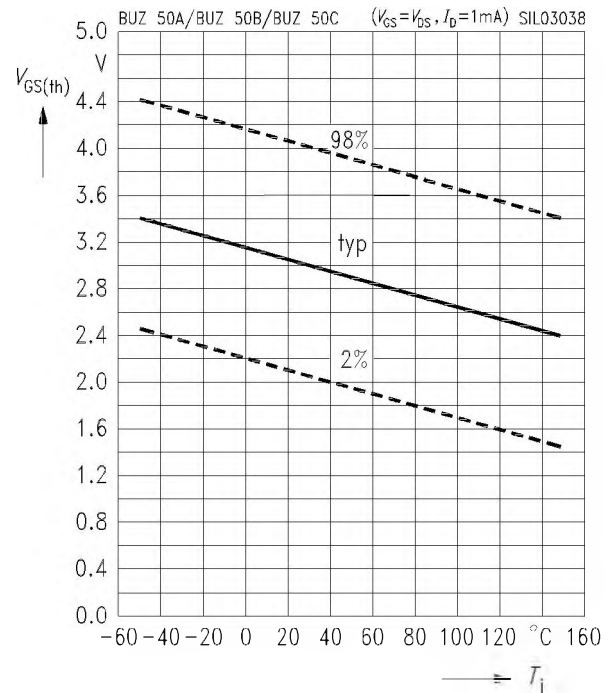

Typ. capacitances

$$C = f(V_{DS})$$

parameter: $V_{GS} = 0 \text{ V}, f = 1 \text{ MHz}$

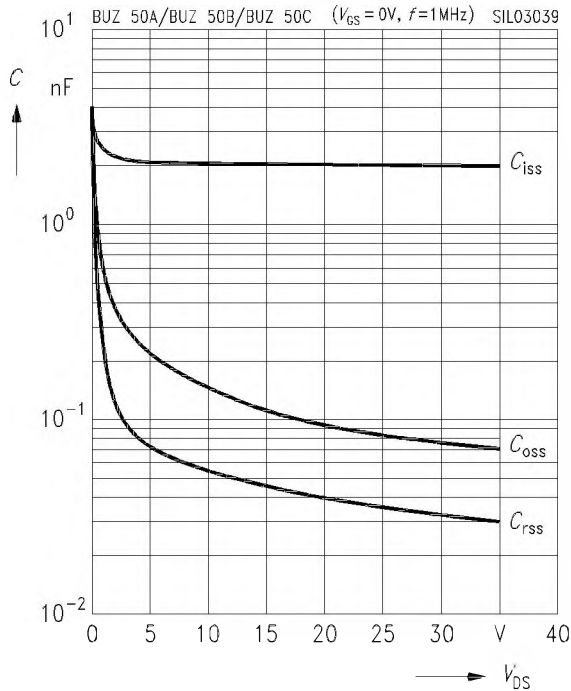

Drain current

$$I_D = f(T_C)$$

parameter: $V_{GS} \geq 10 \text{ V}$

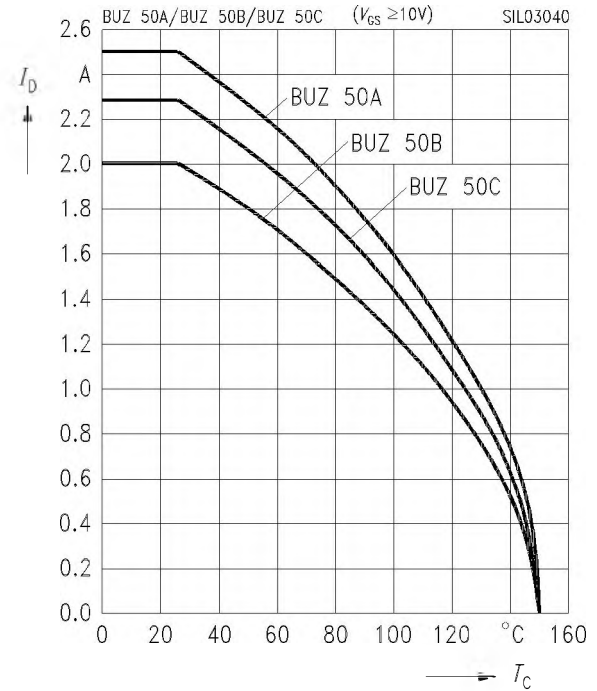

Forward characteristics of reverse diode

$$I_F = f(V_{SD})$$

parameter: $T_j, t_p = 80 \mu\text{s}$, (spread)

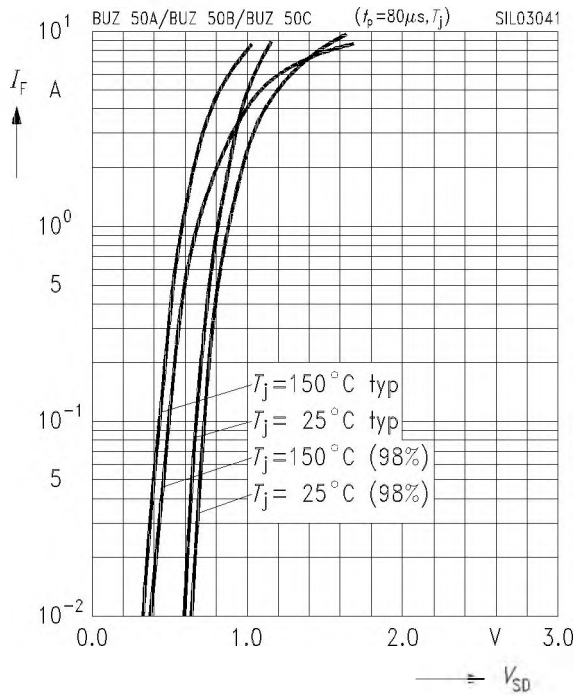

Transient thermal impedance

$$Z_{thJC} = f(t_p)$$

parameter: $D = t_p / T$

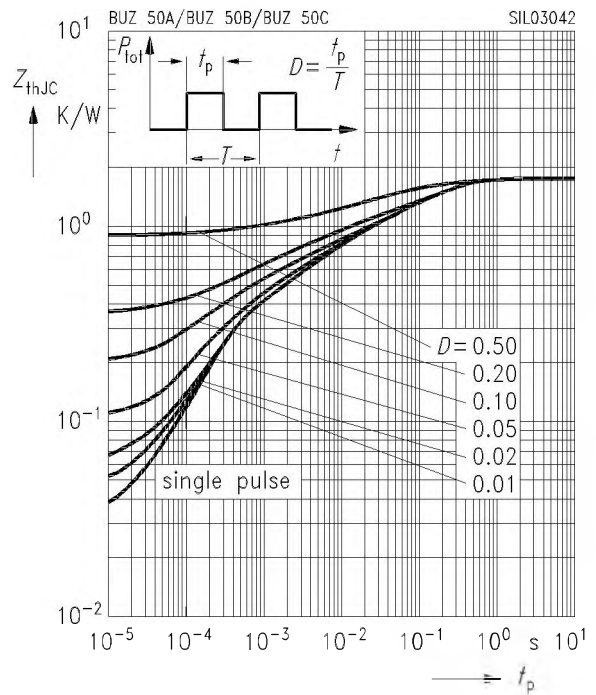

Typ. gate charge

$$V_{GS} = f(Q_{Gate})$$

parameter: $I_{D\ puls} = 3.75\ A$

