

N - CHANNEL ENHANCEMENT MODE POWER MOS TRANSISTOR MODULE

TYPE	V _{DSS}	R _{DS(on)}	I _D
SGS30MA050D1	500 V	0.20 Ω	30 A

- ISOLATED POWERMOS MODULE
- HIGH POWER
- FAST SWITCHING
- EASY DRIVE
- EASY TO PARALLEL

INDUSTRIAL APPLICATIONS:

- SWITCHING MODE POWER SUPPLIES
- UNINTERRUPTIBLE POWER SUPPLIES

N - channel enhancement mode POWER MOS field effect transistor. Easy drive and fast switching of this TRANSPACK module make it ideal for high power, high speed switching applications. Typical applications include DC motor control (variable frequency control) switching mode power supplies, uninterruptible power supplies, DC/DC convertors and high frequency welding equipment. The large RBSOA and absence of second breakdown in POWER MOS make this TRANSPACK module very rugged. This, together with the isolated package with its optimised thermal performance, make this module extremely effective in high power applications.

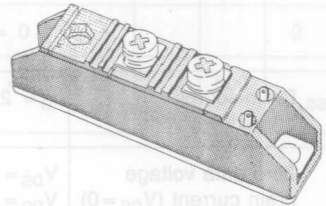

TO-240

INTERNAL SCHEMATIC DIAGRAM

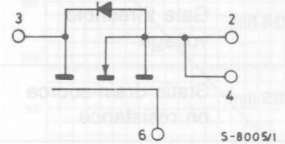

ABSOLUTE MAXIMUM RATINGS

V _{DS}	Drain-source voltage (V _{GS} =0)	500	V
V _{DGR}	Drain-gate voltage (R _{GS} =20 KΩ)	500	V
V _{GS}	Gate-source voltage	±20	V
I _D	Drain current (cont.) at T _c =25°C	30	A
I _D	Drain current (cont.) at T _c =100°C	19	A
I _{DM}	Drain current (pulsed)	120	A
P _{tot}	Total dissipation at T _c < 25°C	400	W
	Derating factor	3.2	W/°C
T _{stg}	Storage temperature	-65 to 150	°C
T _j	Max. operating junction temperature	150	°C
V _{ISO}	Insulation withstand voltage (AC)	2500	V

THERMAL DATA

$R_{thj - case}$	Thermal resistance junction-case	max	0.31	°C/W
$R_{thc - h}$	Thermal resistance case-heatsink	max	0.20	°C/W

ELECTRICAL CHARACTERISTICS ($T_j = 25^\circ\text{C}$ unless otherwise specified)

Parameters	Test Conditions	Min.	Typ.	Max.	Unit
------------	-----------------	------	------	------	------

OFF

$V_{(BR) DSS}$	Drain-source breakdown voltage	$I_D = 2\text{ mA}$	$V_{GS} = 0$	500		V
I_{DSS}	Zero gate voltage drain current ($V_{GS} = 0$)	$V_{DS} = \text{Max Rating}$ $V_{DS} = \text{Max Rating} \times 0.8$	$T_j = 125^\circ\text{C}$		500 2	μA mA
I_{GSS}	Gate-body leakage current ($V_{DS} = 0$)	$V_{GS} = \pm 20\text{ V}$			± 400	nA

ON*

$V_{GS(th)}$	Gate threshold voltage	$V_{DS} = V_{GS}$	$I_D = 2\text{ mA}$	2	4	V
$R_{DS(on)}$	Static drain-source on resistance	$V_{GS} = 10\text{ V}$	$I_D = 15\text{ A}$		0.20	Ω

DYNAMIC

g_{fs}	Forward transconductance	$V_{DS} = 25\text{ V}$	$I_D = 15\text{ A}$	15		mho
C_{iss}	Input capacitance	$V_{DS} = 25\text{ V}$ $V_{GS} = 0$	$f = 1\text{ MHz}$		9100	pF
C_{oss}	Output capacitance				1200	pF
C_{rss}	Reverse transfer capacitance				850	pF

SWITCHING

INDUCTIVE LOAD						
$t_{d(on)}$	Turn-on time	$V_{DD} = 250\text{ V}$ $R_l = 50\ \Omega$	$I_D = 15\text{ A}$		120	ns
$(di/dt)_{on}$	Turn-on current slope		$V_l = 10\text{ V}$		100	A/ μs
$t_{d(off)}$	Turn-off delay time				1.5	μs
t_f	Fall time				300	ns

ELECTRICAL CHARACTERISTICS (Continued)

Parameters		Test Conditions		Min.	Typ.	Max.	Unit
I_{SD}	Source-drain current					30	A
I_{SDM}	Source-drain current (pulsed)					120	A
V_{SD}	Forward on voltage	$I_{SD} = 30\text{ A}$	$V_{GS} = 0$			2	V
t_{rr}	Reverse recovery time	$I_{SD} = 30\text{ A}$	$di/dt = 150\text{ A}/\mu\text{s}$			600	ns

* Pulsed: Pulse duration $\leq 300\ \mu\text{s}$, duty cycle $\leq 2\%$

Safe operating areas

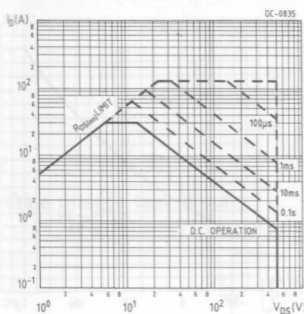

Thermal impedance

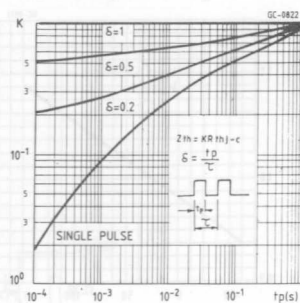

Derating curve

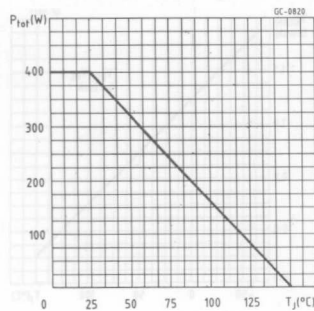

Output characteristics

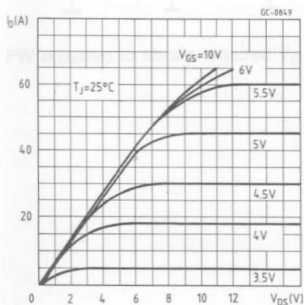

Transfer characteristics

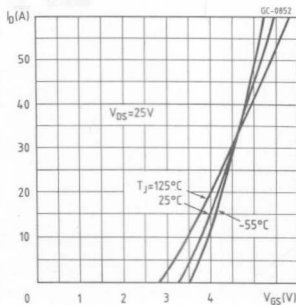

Transconductance

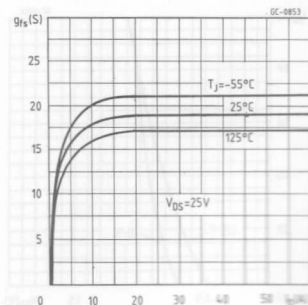

Static drain-source on resistance

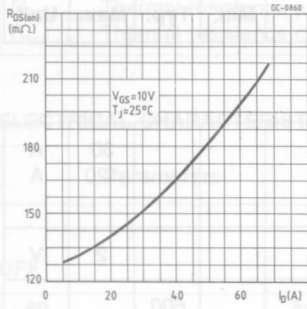

Gate charge vs gate-source voltage

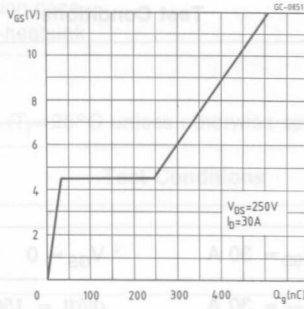

Capacitance variation

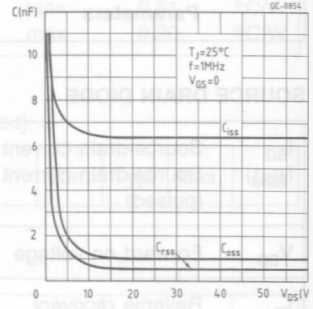

Normalized gate threshold voltage vs temperature

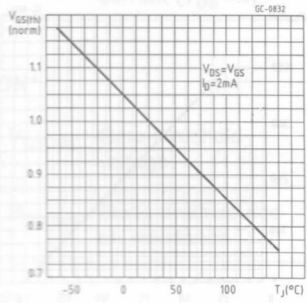

Normalized breakdown voltage vs temperature

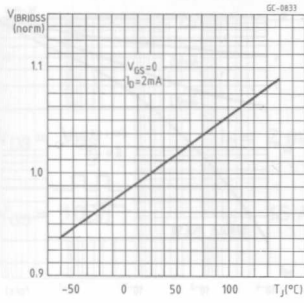

Normalized on resistance vs temperature

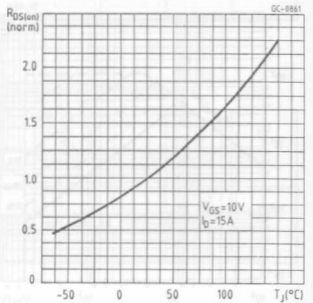

Source-drain diode forward characteristics

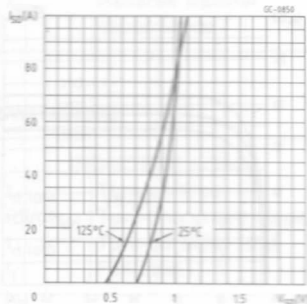

Test circuit for inductive load switching and diode reverse recovery times

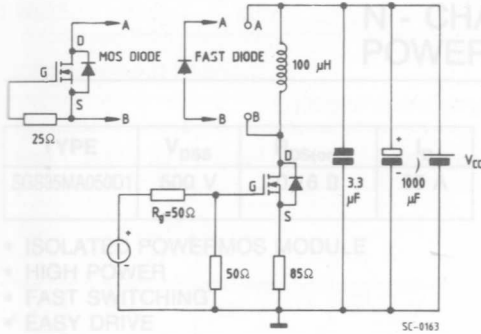

Diode reverse recovery time waveform

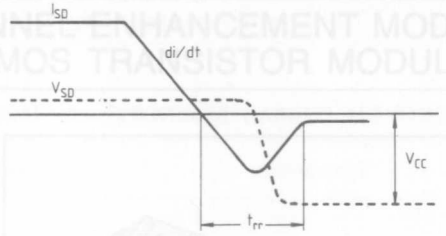

SC-0162



TO-248

- ISOLATED POWER MOS MODULE
- HIGH POWER
- FAST SWITCHING
- EASY DRIVE
- EASY TO PARALLEL

INDUSTRIAL APPLICATIONS:
 • SWITCHING MODE POWER SUPPLIES
 • UNINTERRUPTIBLE POWER SUPPLIES

N-channel enhancement mode POWER MOS field effect transistor. Easy drive and fast switching of this TRANSPACK module make it ideal for high power, high speed switching applications. Typical applications include DC motor control (variable frequency control) switching mode power supplies, uninterruptible power supplies, DC/DC converters and high frequency welding equipment. The large RBSOA and absence of second breakdown in PD mode make this TRANSPACK module very suitable for high power applications. The module's extremely efficient thermal performance, with its optimized thermal performance, make this module extremely effective in high currents.

INTERNAL SCHEMATIC DIAGRAM



Gate charge test circuit

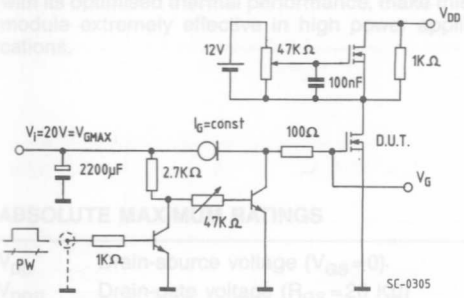

PW adjusted to obtain required V_G

ABSOLUTE MAXIMUM RATINGS

V _{GS}	Gate-source voltage (V _{GS} = 0)	500	V
V _{DS}	Drain-source voltage (R _{DS(on)} = 2.0)	500	V
V _{GS}	Gate-source voltage	±20	V
I _D	Drain current (cont.) at T _c = 25°C	35	A
I _D	Drain current (pulsed)	22	A
I _{DM}	Drain current (pulsed)	140	A
P _{TOT}	Total dissipation at T _c < 25°C	400	W
Derating factor		3.2	W/°C
T _{stg}	Storage temperature	-65 to 150	°C
T _{op}	Max. operating junction temperature	150	°C
V _{ISO}	Insulation withstand voltage (AC)	2500	V